

**COMPETITION SCHEDULE**

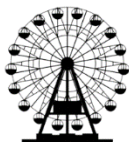

**CAIRNS  
SHOW**



**16TH - 18TH  
JULY 2025**

**SECTION  
23, 24, 25, 26, 27,  
28, 29 & 31  
ARTS & CRAFT**



## CAIRNS SHOW COMMITTEE 2025

Honourary Patron:	Mr. Francis (Ley) James
President:	Mr. Ian Allen
Senior Executive Vice President:	Mr. Desmond Tong
Treasurer:	Ms. Narelle Phipps
Assistant Treasurers:	Mr. Christopher Van Dorssen Mrs. Linda Halliwell
Executive Vice President:	Mr. Bevan Clayton Mr. Glen Hunter Mr. Francis (Ley) James Mr. Nathan Lee Long
Management Committee:	Mrs. Carolyn Allen Ms. Margrit Allen Mr. Kent Hams Mr. Leslie Plath Mr. Daniel Sale Mr. Michael Tonion Mr. Louis Underwood
General Committee:	Ms. Judy Alyce Mrs. Janice Anderson Mr. Raven Cook Mr. Michael Fischer Mr. David Green Mr. Dean Hault Ms. Amanda Hunter Ms. Glenda McAuliffe Mr. Warren March Mr. Malcom O'Hara Mr. Robert O'Malley Mr. Michael Pattini Mr. William (Bill) Smith Mrs. Christine Stoddart Mr. Robert Stoddart

## CAIRNS SHOW STAFF 2025

Manager/Secretary:	Mr. Ian Moller-Nielsen
Entertainment/Competitions Coordinator:	Miss. Amy Jones / Miss. Heather Rowlands
Venues/Sites Coordinator:	Ms. Emily Barker
Finance Officer:	Mrs. Naomi Stewart
Receptionist:	Miss. Heather Rowlands / Miss. Jolena Takai Mr. Anthony Miano
Groundsmen:	Mr. Adam Pritchard Mr. Jeremy Pyke

**WELCOME FROM THE PRESIDENT**

Welcome to the largest regional agricultural show, where we proudly showcase the very best of Far North Queensland's agricultural, pastoral, mining, and cultural industries. We are passionate about bringing the country to the city, celebrating our region's rich heritage and vibrant community spirit.

Each year, this event brings together a diverse range of agricultural, cultural, and artistic experiences designed for children, young people, and families from local, regional, and remote communities. These activities are not only educational and entertaining but also create wonderful opportunities for families to connect and make lasting memories.

The Cairns Show is also home to a variety of exciting competitions, where exhibitors and competitors from across the region put their skills, craftsmanship, and dedication on display. From livestock judging, equestrian events, and woodchopping contests to arts, photography, cooking, and horticulture exhibits, these competitions highlight the incredible talent and hard work within our community. Whether you're a seasoned competitor or a first-time entrant, the competitive spirit of the Show is an integral part of what makes this event so special.

The Cairns Show and its grounds stand as a testament to the dedication of our region, proudly hosting the largest Showmen's Guild entertainment outside of Brisbane's EKKA.

I would like to extend my sincere gratitude to our hardworking staff, Committee, and volunteers, whose tireless efforts behind the scenes make this event possible. Your commitment and dedication do not go unnoticed.

To our visitors—thank you for being part of this celebration. Your support and enthusiasm are what make the Cairns Show such a special event year after year.

A heartfelt thank you also goes to our generous sponsors. Your contributions are invaluable in ensuring we continue to deliver the high-quality show that our community has come to know and love.

With an exciting lineup of attractions, entertainment, competitions, and experiences, there's so much to see and do—you'll be hard-pressed to fit it all into just one day!

So come along, immerse yourself in the fun, and enjoy everything your local show has to offer.



Mr. Ian Allen

**President, Cairns Show Association**

**Cairns Agricultural, Pastoral, and Mining Association**



## ESSENTIAL SHOW INFORMATION

### Cairns Show

**Wednesday 16<sup>th</sup>, Thursday 17<sup>th</sup>, and Friday 18<sup>th</sup> July 2025**

#### **Gate Opening Times:**

9am to 9pm daily - *some attractions closing times may vary.*

#### **Cairns Show Map:**

The Map is available at all Gate Entrances as well as in the Cairns Show Guide, online via the Cairns Show Website, Facebook, and Instagram pages.

#### **Gate Entrances:**

1. Corner of Severin St and Mulgrave Rd (Main Gates).
2. Quigley Street.
3. Mulgrave Rd, in front of the Fred Moule Exhibition Centre.
4. Scott Street.

#### **Taxi Ranks:**

1. Mulgrave Rd, in front of the Honey Providore Horticulture Pavilion.
2. Scott St, near St Augustine's College.
3. Corner of Mulgrave Rd and Severin St.

#### **Bus Stops:**

Sunbus Pickup and Drop Offs Points:

1. To the City – Mulgrave Road opposite the Show Ground Main Entrance
2. From the City – Mulgrave Road in front of the Cairns Youth Centre
3. Disabled Set down is the Corner of Mulgrave Road and Severin Street.

#### **Accessible Parking:**

Parking Bay Locations:

1. 5 bays in Severin Street, near Mulgrave Road
2. 5 bays in Severin St, outside St Augustine's College Swimming Pool.

#### **Toilets:**

Please refer to the Cairns Show Map for Toilet locations.

#### **ATMS:**

1. Immediately inside the Main Gate Entrance in front of the Cairns Show Office.
2. Outside the Fred Moule Exhibition Centre.
3. Immediately inside the Scott St Entrance next to the Sideshow Alley Rides.

#### **First Aid:**

1. Medical Outpost, near the Main Gate Entrance.
2. Clive Gordon Main Arena (Centre Ring).
3. Opposite Animal Nursery.

#### **Smoking:**

The Show is a smoke-free environment. Smoking is only permitted in signed, designated areas. Please refer to the Cairns Show Map for Smoking areas.

#### **Cloakroom:**

Next to the Show Office, Volunteers from the FNQ Hospital Foundation will look after your items while you enjoy the Show. There is FREE sunscreen available.

#### **Wheelchair/Trolley Hire:**

Unfortunately, we do not have Wheelchair or Trolley Hire at the Cairns Show. Please come prepared and refer to the Cairns Show Map for Rest and First Aid locations.

#### **Dogs & Animals:**

Dogs & Animals are not permitted at the Cairns Show! If you bring an animal with you will be denied entry. Exceptions to this: Service & Guide Dogs, or Animals approved for medical purposes (certificate/identification of approval will need to be shown to gate staff/security). Competitors competing in the Cairns Show Association Dog Show Championship will be able to enter the Dog Show/Campgrounds areas only – please enter via Quigley St.

## GATE ADMISSION CHARGES

### TICKETING INFORMATION

1. Purchasing Tickets Online is strongly encouraged. To purchase Tickets Online, visit the Cairns Show website at [www.cairnsshow.com.au](http://www.cairnsshow.com.au).
2. Presold (discounted) Tickets will be available at Earlville Shopping Town and Online. To purchase Presold Tickets please refer to the information below.
3. Tickets can be purchased At the Gates during the Show. Cashless payment is preferred, however, limited ATMS will be available around the grounds. Please refer to the Cairns Show Map for ATM locations.
4. Please note: a Transaction Fee Per Order will be payable to the Ticketing Merchant for all Ticket Orders online and in person.
5. By purchasing a Ticket, you agree to the Terms & Conditions outlined on our website.

### PRESOLD TICKETS

You can buy discounted Presold Tickets either online at [www.cairnsshow.com.au](http://www.cairnsshow.com.au) or at Earlville Shopping Town from Friday 5<sup>th</sup> to Monday 14<sup>th</sup> July, between 9am and 5pm. On Tuesday 15<sup>th</sup> July, tickets will be available at the Main Gates of the Cairns Showgrounds from 9am to 5pm, but only online purchases will be available after 5pm.

#### Presold Ticket Types:

Valid for One Day – Any Day of the Cairns Show.

- **Adult (18 Years and Over):** \$27
- **Concession/Pension:** \$23\*
- For individuals 14 Years and Over with a Valid Student ID or Pensioners Card.
- \*Please note: a discounted Concession/Pension Voucher will be published in the local newspaper, offering Concession/Pensioners One Day – Any Day Entry at \$21. Refer to the Cairns Show website for more information.
- **Child (5 Years to Under 14 Years):** \$15
- **Child (Under 5):** Free
- **Family Pass (2 Adults & 2 Children):** \$70
- Children must be aged 5 Years to Under 14 Years.
- Family members will receive individual tickets, allowing them to enter at different times during the same day.

### TICKETS AT THE GATE

Starting from 12am Wednesday 16<sup>th</sup> July, ticket prices will revert to the standard gate prices as listed below.

#### Ticket at the Gate Types:

Valid for One Day – Any Day of the Cairns Show.

- **Adult (18 Years and Over):** \$30
- **Concession/Pension:** \$24
- For individuals 14 Years and Over with a Valid Student ID or Pensioners Card.
- **Child (5 Years to Under 14 Years):** \$16
- **Child (Under 5):** Free
- **Family Pass (2 Adults & 2 Children):** \$75
- Children must be aged 5 Years to Under 14 Years.
- Family members will receive individual tickets, allowing them to enter at different times during the same day.

### BONUS DOLLARS

1. Bonus Dollars are NOT available for purchase online.
2. One sheet of Bonus Dollars is \$25 for a \$30 value.
3. Bonus Dollars may only be used in Sideshow Alley at the Cairns Show, and can be redeemed on the following: Rides, Food and Games. NOT redeemable on Showbags. Bonus Dollars are not transferable and cannot be replaced if lost, stolen or misplaced. Unused tickets are non-refundable.

## CAIRNS SHOW ASSOCIATION MEMBERSHIP

### MEMBERSHIP INFORMATION

Become a Member of the Cairns Agricultural, Pastoral and Mining Association and receive a range of benefits at the Cairns Show, Cairns Show Wine Awards, the Cairns Show Auto Spectacular, and throughout the year.

1. To Apply for Membership and more information on Benefits, visit our website.
2. ALL Membership Types can be used for THREE DAY entry of the Cairns Show.
3. 2025 Membership Applications/Renewals open January 2025, and close Friday 11<sup>th</sup> July 2025.
1. Membership year ending 31st December 2025. The Cairns Show Association has the right to refuse your application. Limited Applications are available and accepted.
2. By purchasing a Cairns Show Ticket, Membership, and/or Bonus Dollars, the holder agrees to the CAPMA Copyright, Privacy Policy, and Disclaimer. Please refer to our website for more information.

### MEMBERSHIP TYPES

**Annual Member:** \$95 or pay \$950 for a Permanent 10-Year Membership.

CAPMA members 18 years and over receive the following benefits:

1. One (1) Member's Shield gaining unrestricted, three-day entry to the Cairns Show (single person entry).
2. One (1) Member's Guest Shield gaining unrestricted, three-day entry to the Cairns Show (non-transferable, single person entry).
3. Access to the De Jarlais Member's Pavilion during the Cairns Show. Buffet and bar not included in Membership (payable to vendor on the day).
4. Access to Member's Exclusive Deals during the Cairns Show.

**ShowTime Member:** \$55

As a ShowTime promotion only, ShowTime Members receive the following benefits:

1. One (1) Member's Shield gaining unrestricted, three-day entry to the Cairns Show (single person entry).
2. Access to the De Jarlais Member's Pavilion during the Cairns Show. Buffet and bar not included in Membership (payable to vendor on the day).
3. Access to Member's Exclusive Deals during the Cairns Show.

**Concession Member:** \$17

CAPMA Members between 14 years to under 18 years receive the following benefits:

1. One (1) Member's Shield gaining unrestricted, three-day entry to the Cairns Show (single person entry).
1. Access to the De Jarlais Member's Pavilion during the Cairns Show. Buffet and bar not included in Membership (payable to vendor on the day). Those under the age of 18 years must be always accompanied by an Adult!

Those 18 years or over receive the above and:

1. MUST hold a and present Valid Concessional Student Identification card.
2. Access to Member's Exclusive Deals during the Cairns Show.

**Child Member:** \$12

CAPMA Members 5 to under 14 years receive the following benefits:

1. One (1) Member's Shield gaining unrestricted, three-day entry to the Cairns Show (single person entry).
2. Access to the De Jarlais Member's Pavilion during the Cairns Show. Buffet and bar not included in Membership (payable to vendor on the day). Those under the age of 18 years must be always accompanied by an Adult.

## GENERAL CONDITIONS - COMPETITIONS

### ENTRY & COMPETITIONS

This Show operates under the regulations set forth by the Queensland Chamber of Agricultural Societies, the constitution, and rules of this Society, as well as any regulations specified within the individual sections of this Show's Schedule. In the event of any conflict between these rules and regulations, those outlined in the Schedule of this Society shall take precedence. For detailed information on the rules and regulations of the Queensland Chamber of Agricultural Societies, please visit [www.queenslandshows.com.au](http://www.queenslandshows.com.au).

By participating in any class outlined in this Schedule, all individuals agree to indemnify the CAIRNS AGRICULTURAL PASTORAL AND MINING ASSOCIATION against liability for any accidents, damages, losses, or illnesses to any Exhibit, Exhibitor, or Competitor. Additionally, participants acknowledge that all Competitions are under the complete control of the CAIRNS AGRICULTURAL PASTORAL AND MINING ASSOCIATION, whose decisions in all matters are final.

### THE CAIRNS AGRICULTURAL PASTORAL AND MINING ASSOCIATION

1. No Competition Entries or Membership Applications will be taken over the phone.
2. A Chief Steward will be assigned to each Section to represent it in all matters. Failure to adhere to lawful directions from appointed Stewards, Committee, or Staff, or engaging in verbal or physical abuse, will result in Disciplinary Action, which may include exclusion from further Competitions and/or the Cairns Showgrounds.
3. Judges will be appointed, and their decisions will be final. No verbal or written communication will be entertained or considered.
4. **The organizers reserve the right to make any necessary decisions, inclusions, or changes to this Schedule, including Conditions of Entry and Special Regulations, without further notice.**
5. By entering this Competition, exhibitors acknowledge their compliance with these Conditions.
6. Judges at The Cairns Show are prohibited from having any prior or during judging information beyond what is provided by the Cairns Agricultural Pastoral and Mining Association. Vice Presidents are not permitted to compete in sections under their control.

### ANIMAL AND BIRD EXHIBITORS

1. All animal and bird exhibitors are required to sign an Exhibit Health Declaration upon delivering their entry and must adhere to the health requirements outlined in this document. Exhibit Health Declarations can be obtained from the Show Office or the website [www.cairnsshow.com.au](http://www.cairnsshow.com.au).
2. Owners of animals are responsible for any veterinary fees incurred. The Cairns Show will not assume responsibility for any veterinarian expenses.
3. Please take note of the following conditions for entry into the grounds:
  - a. Glass items are prohibited on the grounds.
  - b. All electrical leads must be appropriately tagged in accordance with relevant industrial regulations.
  - c. Dogs must be kept on a leash at all times.

### PRIZE MONEY & GST

The Prize Money listed in the Schedule does not include GST. GST will be added to the Prize Money for exhibitors who are registered for GST purposes. The Association will issue a "Recipient Created Tax Invoice" to exhibitors who are registered for GST purposes.

### PRIVACY STATEMENT

The Cairns Show Association uses the information you provide in Membership or entry applications to offer member services and to organize and conduct competitions at the Cairns Show. By applying for Membership or entering our competitions, you consent to provide details such as your name, address, and exhibit details. Competition details may be shared with the media and included in publications. Your information will not be disclosed for any other purpose without your consent, except as required by law.



**CAIRNS  
SHOW**

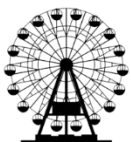

**16TH - 18TH  
JULY 2025**

**SECTION 23  
BUMMA BIPPERA 98.7  
INDIGENOUS ARTS**

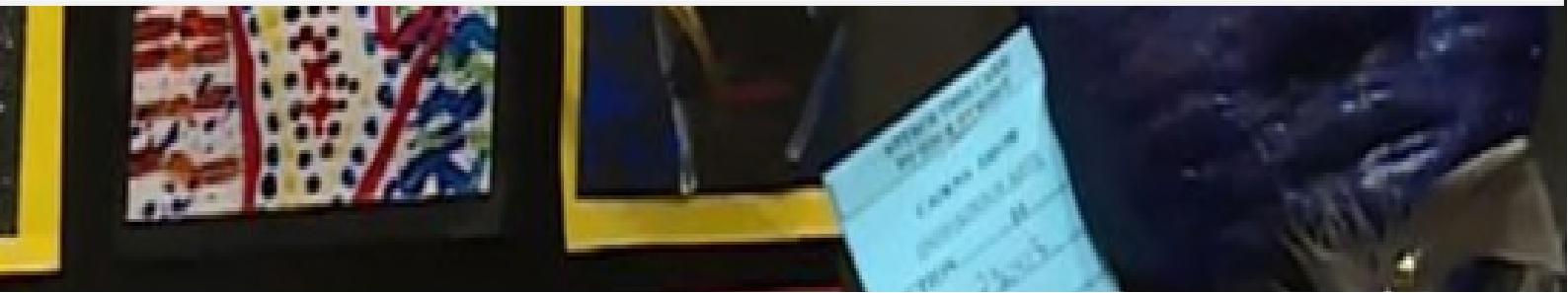



## SECTION 23 BUMMA BIPPERA 98.7 INDIGENOUS ARTS

### OFFICIALS

Chief Steward: Miss. Heather Rowlands (Competitions Coordinator)

### KEY INFORMATION

**Entry Fee:** \$FREE

**Prize:** As Stated

**Entries Close:** 4pm Friday 20th June.

**Delivery of Exhibits:** 12pm-5pm Wednesday 9th July - Cairns Show Office

**Judging:** 10am Wednesday 16th July 2025

### SPONSORS

The Cairns Show Association wishes to record its sincere appreciation to the following Sponsors who have contributed to this area.

**Bumma Bipperra 98.7, and Showbag Warehouse**

### HOW TO ENTER

1. Complete an Entry online or in person at the Cairns Show Office, or post via PO Box 811 Bungalow, QLD 4870.
2. Entries will not be accepted over the phone or after the closing date.
3. Pay for Entry Fees online, by direct deposit, or in person at the Cairns Show Office (cash accepted).
4. Entries must be delivered to the designated part of the Showgrounds by the due date time and date shown.

### AFTER THE SHOW

1. **Exhibits NOT collected by Friday 22nd August 2025 will become Property of the Cairns Show Association.**
2. Prize Money can be collected between 9am and 4pm Monday to Friday 4th August to 29th August from the Show Office if your total prize money is less than \$50.
3. Proof of identity is required to collect Prize Money. If you are collecting prize money on behalf of someone else, a letter of authorisation from that person will be required.
4. All Prize Money less than \$50 not collected by 29th August, 4pm will be returned to the Cairns Show Association Funds.
5. Prize money of \$50 and over will be deposited to the entrant's nominated bank account after 29th August.
6. Results will be available from the [Cairns Show website](#) AFTER the conclusion of the Show.

## SPECIAL REGULATIONS

### SPECIAL REGULATIONS

1. Refer to General Conditions of Entry and Competition in the front of this Schedule.
2. This competition is for Indigenous arts and crafts only. Exhibits must have an Indigenous element either traditional or modern.
3. Indigenous arts are open to all ethnic backgrounds.
4. All exhibits must be the original work of the exhibitor.
5. Each exhibit may be entered in only one class.
6. All exhibits in Junior Classes must include date of birth on entry form.
7. In the event of an exhibit in any one class not being worthy of a prize, no prize money will be awarded.
8. Exhibits will be displayed in a designated Gallery in the Fred Moule Pavilion.
9. Exhibits are not limited to size restrictions.
10. Canvas may be used.
11. No free passes available to exhibitors

## SECTION 23 BUMMA BIPPERA 98.7 INDIGENOUS ARTS

Class 23001 Primary School Years 1-3

**Open, Any Medium, Any Subject**

**Prize:** 1st - \$15 + Trophy + Sash, 2nd - \$1, 3rd - \$5

Class 23002 Primary School Years 4-6

**Open, Any Medium, Any Subject**

**Prize:** 1st - \$20 + Trophy + Sash, 2nd - \$15, 3rd - \$8

Class 23003 High School Students to Under 18 Years

**Open, Any Medium, Any Subject**

**Prize:** 1st - \$60 + Trophy + Sash, 2nd - \$40, 3rd - \$20

Class 23004 Adults

**Open, Any Medium, Any Subject**

**Prize:** 1st - \$100 + Trophy + Sash, 2nd - \$60, 3rd - \$30



**CAIRNS  
SHOW**

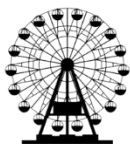

**16TH - 18TH  
JULY 2025**

**SECTION 24  
FIBRECRAFTERS**

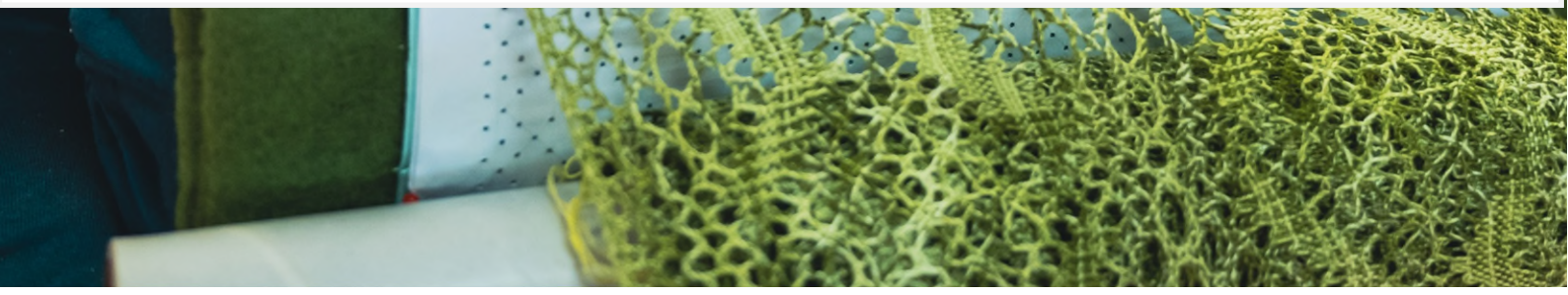

## SECTION 24 FIBRECRAFTERS

### OFFICIALS

Chief Steward: Ms. Carol Coates

### KEY INFORMATION

**Entry Fee:** FREE

**Prize:** 1st - \$15 + Card = 5 Points, 2nd - \$8 + Card = 3 Points, 3rd Card = 1 Point

**Entries Close:** 4pm Friday 20th June.

**Delivery of Exhibits:** 9am - 4pm Thursday 10th and Friday 11th July - Arts & Crafts Hall

**Judging:** 9am Saturday 12th July 2024

**Collection of Exhibits:** 10am-12pm Saturday 19th July - Main Arena (Centre Ring) side of the Arts & Crafts Pavilion. Out of town exhibitors may collect exhibits after the Fireworks for 30 minutes on Friday 18th July BY PRIOR ARRANGEMENT ONLY.

### SPONSORS

The Cairns Show Association wishes to record its sincere appreciation to the following Sponsors who have contributed to this area.

**Fibrecrafters FNQ Inc.**

### HOW TO ENTER

1. Complete an Entry online or in person at the Cairns Show Office, or post via PO Box 811 Bungalow, QLD 4870.
2. Entries will not be accepted over the phone or after the closing date.
3. Entries must be delivered to the designated part of the Showgrounds by the due date time and date shown.
4. Exhibitors will receive Entry and Class Cards.
5. All Class cards to be placed on the bottom right-hand corner of exhibit.
6. A small, sealed envelope with your name and contact number must be attached to the back of exhibit prior to delivery.

### AFTER THE SHOW

1. Exhibits not collected by 29th August 2025 will automatically become the property of the Cairns Show Association.
2. Prize money under the value of \$50 and Prize Certificates can be collected between 9am and 4pm, Monday to Friday, from Monday 4th August to Friday 29th August 2025 from the Show Office.
3. Any prize money over the value of \$50 will be directly deposited to your account from Monday 4th August to Friday 29th August.
4. Proof of identity is required to collect Prize Money. If you are collecting prize money on behalf of someone else, a letter of authorization from that person will be required.
5. Entrants who have not provided their account details will be contacted via the details presented on their Entry Form.
6. ALL Prize Money not collected by 4pm on Friday 29th August 2025 will be returned to the Cairns Show Association Funds and unable to be collected.
7. A 'local' is defined as residing between the areas of Palm Cove & Gordonvale and west to the range.
8. Results will be available AFTER the conclusion of the Show from the Cairns Show Website [www.cairnsshow.com.au](http://www.cairnsshow.com.au).

## SPECIAL REGULATIONS

### PLEASE READ SPECIAL REGULATIONS FOR THE CLASS YOU ARE ENTERING THOROUGHLY

1. Refer to General Conditions of Entry and Competition in the front of this Schedule.
2. All exhibits must be the sole work of the exhibitor/s. Exhibits created in tutored workshops are accepted for competition in Class 24025 only.
3. Each exhibit may be entered in only one (1) class.
4. All exhibits must be completed in the twelve (12) months prior to the 2025 Cairns Show.
5. Exhibits entered in previous Cairns Shows are accepted for competition in Class 24024 only and must be reconstructed into an original exhibit different from the one previously judged.
6. The Judge reserves the right to alter the Class of an exhibit.
7. Exhibits in Classes 24001, 24002, 24003, 24004, 24017 to be accompanied by a completed sample (minimum 10 cm square), mounted on A5 size WHITE heavy card.
8. Attach a sample of raw material to exhibits in Classes 24001, 24002, 24003, 24004, 24009, 24010, 24017, 24018, 24019, 24020, 24021 and 24024.
9. Exhibits in class 24022, a joint effort must be accompanied by a description of materials and technique/s used, must reflect the shared work of two (2) or more people and will be judged as one (1) exhibit. Prize-winning joint exhibits will have full points awarded to each participant.
10. To assist the Stewards in arranging and dispatching the exhibits after the Show, attach a sealed envelope containing the owner's name and address to the back of each exhibit.
11. All exhibits forwarded by mail must include return postage.
12. No free passes available to exhibitors.
13. Exhibits for sale must be marked clearly with price. Exhibits not for sale must be marked clearly "NFS". Sold items must remain until Saturday of Show.
14. Commission of 20% will apply to all exhibits sold and must be included in the sale price. Please liaise with the Chief Steward.



## SINGLE EFFORT

### SPINNING

Class 24001 Novice - Hand-Spun Yarn

**Not more than 3 years' experience, and not previously awarded a prize in classes 24001, 24002, 24003 or 24004. Piled, natural fibre, no blends, 1 skein (minimum 25 metres), washed.**

Class 24002 Natural Fibre - Hand-Spun Yarn

**Natural fibre, no blends, 1 skein (minimum 25 metres), washed.**

Class 24003 Fibre Blend - Hand-Spun Yarn

**Fibre blend, commercial optional, 1 skein (minimum 25 metres), washed.**

Class 24004 Designer - Hand-Spun Yarn

**Hand-Spun Designer Yarn, not less than 25% hand-spun fibre, 1 skein (minimum 25 metres).**

### DYEING

Class 24005 Natural Dyes - Hand-Dyed Yarn

**Natural dyes, 1 skein (minimum 25 metres), washed.**

Class 24006 Commercial Dyes - Hand-Dyed Yarn

**Commercial dyes, 1 skein (minimum 25 metres), washed.**

Class 24007 Natural or Commercial Dyes - Hand-Dyed Article or Garment

### Weaving

Class 24008 Hand-Woven Fabric

**Any Medium.**

Class 24009 100% Hand-Spun Yarn - Hand-Woven Article or Garment

**Natural fibre/s.**

Class 24010 Any Medium - Hand-Woven Article or Garment

Class 24011 Hand-Woven Tapestry Weaving

**Any Medium framed or unframed, ready to hang.**

### FELTING

Class 24012 Hand-Felted - Wearable Garment or Accessory

**Any Techniques - Example: sculpture, bag, shawl.**

Class 24013 Hand-Felted - Non-Wearable Article

**Any Techniques - Example: sculpture, rug, wall piece.**

Class 24014 Nuno Felted - Wearable Art Garment or Article

### BASKETRY

Class 24015 Hand-Woven Article

**Using Basketry Techniques, Any Medium.**

Class 24016 Hand-Crafted Basketry or Sculpture

**Using Techniques other than weaving, Any Medium - Example: coiling, sewing, wrapping.**

**SINGLE EFFORT – CONTINUED****OTHER TECHNIQUES**

Class 24017 Hand-Crafted Unique Creative Yarn

**Using Techniques other than spinning or plying, 1 skein (minimum 25 metres) - Any Medium. Fibre, yarn, fabric, plastic, wire or liked, must be stable for the end use.**

Class 24018 Hand-Crafted Article or Sculpture

**Using only RECYCLED materials. Example: fabric, plastic, paper. Attached a sample of raw material or photo of a sample of items used in the whole work cannot be obtained. Write a brief description of materials and techniques used.**

Class 24019 Lace Item

**Any item created from at least two types of lace. Example: hairpin, teneriffe crochet, bobbin, tatting, etc.**

Class 24020 Lace Article or Garment

**Any Technique (describe briefly) and Any Medium.**

Class 24021 Fibrecrafting Techniques - Hand-Crafted Article or Garment

**Using a minimum of 3 Fibrecrafting Techniques. Examples: knitting, dyeing, felting, etc. Description of Techniques used and Any Medium.**

Class 24022 Knitted or Crocheted from Yarn - Hand-Crafted Article or Garment

**Any Article or Garment, knitted or crocheted from any yarn (included natural or synthetic fibres, hand or commercial spun).**

**JOINT EFFORT**

Class 24023 Hand-Crafted Article or Garment/ Other

**Any Technique/s, Any Medium, Any Other Article.**

**ANY OTHER ARTICLE**

Class 24024 Original Article Reconstructed

**From a previous judged article. See Special Regulation 5.**

Class 24025 Any Other Article Not Specified

**SPECIAL CLASS**

Class 24026 Finished - Hand-Crafted Yarn, Article or Garment Created in a Tutored Work

Using Fibrecrafting Techniques with any fabric, material or yarn (if applicable, 1 skein minimum 25 metres)

This is open to all workshop attendees, not just those convened by Fibrecrafters FNQ Inc.

**SECTION 24 FIBRERAFTERS****AWARD FOR EXCELLENCE - \$50**

**Most points overall in classes 24001 to 24026**

**Prize:** Sheila Robertson Perpetual Trophy + \$50.00 Gift Voucher + Sash – **Sponsored by Fibrecrafters FNQ Inc.**

**AWARD FOR EFFORT - \$50**

**This Award encourages diversity of talents. An exhibitor who has entered a minimum of five classes from 24001 to 24026 and earns the highest points other than Award for Excellence recipient. Judge's decision if tied points or if no one qualifies.**

**Prize:** Gladys & Ray Brown Perpetual Trophy + \$50.00 + Sash

**JUDGES AWARD - \$50**

**Awarded to the Judge's choice of one exhibit in Classes 24001 to 24026**

**Prize:** \$50.00 + Sash





## FIBRECRAFTERS FNQ INC.

### CAIRNS CRAFT CLUB

Fibrecrafters FNQ has been operating in the Cairns community since 1980, originally as the Northern Spinners and Weavers. They offer a caring and friendly atmosphere at the Cairns Showgrounds, and in addition they are there to answer any questions you may have about their club.

Their aim is to create an interest in the arts of spinning, weaving and related crafts and to provide facilities and information to encourage members to reach a high standard of proficiency in these crafts and to fully enjoy the pursuit of these arts and crafts.

In addition, they have 600+ library of books and DVDs, looms, spinning wheels and other equipment for members to hire.

### HISTORY

On May 21st, 1980, the Club formed after meeting at TAFE library following a radio ad calling for anyone interested in sharing and learning the art of Spinning and Weaving. Later that year, the Club drafted its constitution and was officially named "The Northern Spinners and Weavers". The club was formed with Sheila Roberson as President.

They incorporated in 2002 and more recently the Club underwent a name change (Fibrecrafters FNQ Inc.) in order to acknowledge the diversity in textile related crafts that it now embraces.

Some of these are basketry, weaving, fabric dyeing, bobbin lace, knitting, crocheting, spinning, tapestry weaving, tatting, jewellery making, felting and traditional as well as contemporary techniques in numerous other crafts.

**Learn new skills and meet new friends. All ages are welcome!!**





**CAIRNS  
SHOW**

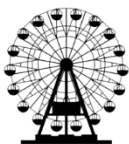

**16TH - 18TH  
JULY 2025**

**SECTION 25  
VISUAL ARTS**



CAIRNS SHOW 2025  
Section 25 - Visual Arts  
Open  
Pottery  
CHAMPION 3 DIMENSIONAL ARTWORK OF  
SHOW  
AWARDED TO: Gregory, Blakey  
JUDGE: Annette Taylor  
STEWARDS: Judith & Alan  
CAIRNS  
SHOW

## SECTION 25 VISUAL ARTS

### OFFICIALS

Chief Steward: Mrs. Lone White

Steward: Mrs. Christina George

### KEY INFORMATION

**Entry Fee:** *As Stated.*

**Prize:** *As Stated + Card.*

**Entries Close:** 4pm Friday 20th June.

**Delivery of Exhibits:** 12pm-6pm Wednesday 9th July - Visual Arts Hall, at the back of and under David Headrick Grandstand opposite Mulgrave Rd.

**Judging:** 10am Sunday 13th July

**Collection of Exhibits:** 9am-12pm Saturday 19th July. No responsibility will be taken for any exhibits left after this time. Exhibits not collected by Friday 29th August will become Property of the Cairns Show Association unless otherwise arranged prior to the conclusion of the Cairns Show.

### SPONSORS

The Cairns Show Association wishes to record its sincere appreciation to the following Sponsors who have contributed to this area.

**Cairns Potters Club, Cairns Art Society, and Showbag Warehouse**

### HOW TO ENTER

1. Complete an Entry online or in person at the Cairns Show Office, or post via PO Box 811 Bungalow, QLD 4870.
2. Entries will not be accepted over the phone or after the closing date.
3. Pay for Entry Fees online, by direct deposit, or in person at the Cairns Show Office (cash accepted).
4. Entries must be delivered to the designated part of the Showgrounds by the due date time and date shown.
5. Exhibit (Class) Cards will be posted to the Entrant after the entry closing date or may be collected from the Cairns Show Office by prior arrangement.

### AFTER THE SHOW

1. **Exhibits not collected by 29th August 2025 will automatically become the property of the Cairns Show Association.**
2. Prize money under the value of \$50 and Prize Certificates can be collected between 9am and 4pm, Monday to Friday, from Monday 4th August to Friday 29th August 2025 from the Show Office.
3. Any prize money over the value of \$50 will be directly deposited to your account from Monday 4th August to Friday 29th August.
4. Proof of identity is required to collect Prize Money. If you are collecting prize money on behalf of someone else, a letter of authorization from that person will be required.
5. Entrants who have not provided their account details will be contacted via the details presented on their Entry Form.
6. ALL Prize Money not collected by 4pm on Friday 29th August 2025 will be returned to the Cairns Show Association Funds and unable to be collected.
7. A 'local' is defined as residing between the areas of Palm Cove & Gordonvale and west to the range.
8. Results will be available AFTER the conclusion of the Show from the Cairns Show Website [www.cairnsshow.com.au](http://www.cairnsshow.com.au).

## SPECIAL REGULATIONS

### PLEASE READ SPECIAL REGULATIONS FOR THE CLASS YOU ARE ENTERING THOROUGHLY

1. Each artist is restricted to a maximum of four (4) entries overall.
2. Each artist is restricted to a maximum of two (2) entries per class including Sculpture and Pottery.
3. All exhibits must be the original and unaided work of the exhibitor.
4. All exhibits must have been executed within the last twelve (12) months prior to the 2025 Cairns Show. Previous Cairns Show exhibits will not be accepted.
5. No exhibit can be entered into more than one class.
6. All two-dimensional work to be suitably framed and/or presented, securely wired ready for hanging and no larger than 100cm x 100cm. Oversized works and works not able to be hung, will be rejected.
7. Junior two-dimensional works are to be completed on card stock of A4 size, except Classes 25017 - 25022.
8. All exhibits must be clearly marked on the back/base with the exhibitor's name, address, price and whether it is for sale. Exhibits not marked will be classed as not for sale. Commission of 25% will apply to all exhibits sold and must be included in the Sale Price. Stewards will advise artists of persons interested in their artwork.
9. Class card must be attached, on 2D work attach on back, right hand side, allowing to hang and be seen from the front.
10. All exhibits forwarded by mail should be securely packed and arrangements made for return. No costs shall be incurred by the Cairns Show or their Agents.
11. Exhibitors shall allow their works to be photographed or reproduced for press and television during the exhibition period.
12. No exhibits are to be removed from the Cairns Showgrounds prior to 9.00am Saturday 19th July 2025.
13. All exhibits MUST be collected between 9:00am and 12:00pm on Saturday 19th July 2025. No entry will be permitted to be removed before this time. Exhibits must be signed out by a steward (If you are unable to comply - DO NOT ENTER). No responsibility will be taken for any exhibits left in the grandstand area after this time. If not collected, the exhibit will become Property of the Cairns Show Association unless otherwise arranged.
14. All entries must be signed in upon arrival and signed out by a steward at collection.
15. No free passes available to exhibitors.
16. All exhibits are to be delivered to the Visual Arts Hall at the back of the Headrick Grandstand at the times stated. No late entries will be accepted whatsoever. The Chief Steward's decision will be final.
17. All persons upon entering any class in this Schedule agree to indemnify the CAIRNS AGRICULTURAL PASTORAL AND MINING ASSOCIATION against liability for any accident, damage, loss or illness to any Exhibit, Exhibitor or Competitor and agree that all Competitions are under the complete and total control of the CAIRNS AGRICULTURAL PASTORAL AND MINING ASSOCIATION whose decision in all matters is final.
18. THE CAIRNS AGRICULTURAL PASTORAL AND MINING ASSOCIATION:
19. Will appoint a Chief Steward to each Section as its representative in all matters
20. Will appoint Judges whose decision is final, and
21. reserves the right to make any decisions, inclusions or changes to this schedule including Conditions of Entry and Competition without further notice.

**OPEN****PAINTINGS****Entry Fee:** \$2.50**Prize:** 1st - \$65, 2nd - \$20

Class 25001 Oils

Class 25002 Acrylics

Class 25003 Mixed Media

Class 25004 Watercolour

Class 25005 Graphic - Charcoal, Pen, Pencil, Conte, etc.

Class 25006 Digital Art

**CHAMPION 2-DIMENSIONAL ARTWORK OF SHOW - \$100****Prize:** \$100 + Sash**SCULPTURE****Entry Fee:** \$2.50**Prize:** 1st - \$65, 2nd - \$20

Class 25007 Sculpture

**POTTERY****Entry Fee:** \$2.50**Prize:** 1st - \$65, 2nd - \$20

Class 25008 Pottery - Open

Class 25009 Pottery - Novice

Less Than 3 Years Experience and Not a Previous Winner

**CHAMPION 3-DIMENSIONAL ARTWORK OF SHOW - \$100****Prize:** \$100 + Sash

## QUEENSLAND HERITAGE REGISTER

**Entry Fee:** FREE

**Prize:** 1st - \$100, 2nd - \$50

The Queensland Heritage Register is a list of places that have cultural heritage significance to the people of Queensland showing the pattern of Queensland's history and regional development. They illustrate incredible human endeavours political, social and cultural forces that have shaped our society. Accordingly, places are protected under heritage legislation. Whilst any State Heritage Place may be the subject of this visual arts category, it is expected that interest will be mostly on those State Heritage Places located in the Cairns region.

### State Heritage Places located in the Cairns Region:

1. Cairns Technical College and High School Building
2. Bolanda Centre
3. Hides Hotel
4. Cairns City Library (formerly Cairns City Council Chambers)
5. McLeod St Pioneer Cemetery
6. Adelaide Steamship Co Ltd Building
7. Cairns Wharf
8. Flecker Botanical Gardens
9. St Monica's War Memorial Cathedral
10. Tanks Art Centre
11. The register is located at <https://heritage-register.ehp.qld.gov.au/basicSearch.html>

This category is sponsored by the Heritage Council, the State's independent advisor on heritage matters. The Heritage Council determines what places are entered in the Queensland Heritage Register.

Class 25010 State Heritage Places entered in the Queensland Heritage Register

Visual Arts, Any Medium.

**ADELAIDE STEAMSHIP CO LTD BUILDING**



**ST. MONICA'S WAR MEMORIAL CATHEDRAL**



## JUNIOR SCULPTURE

**Entry Fee:** \$1

**Prize:** 1st - \$10, 2nd - \$5, 3rd - \$2

Class 25011 Sculpture - 12 Years & Under

Class 25012 Sculpture - 13 Years to Under 18 Years

## JUNIOR ART

**Requirements for the below classes age groups 5 Years and Under, and 6-10 Years:**

1. Must be presented unframed and mounted on A4 Card Stock (21cm x 30cm).
2. Canvas is accepted.
3. Limit One (1) Entry per artist, per class.

### **5 YEARS & UNDER**

**Entry Fee:** \$1

**Prize:** 1st - \$8, 2nd - \$4, 3rd - \$2

Class 25013 Oils, Watercolour, Acrylic

Any Subject

Class 25014 Drawing

Pencil, Felt Pen, Crayon, Coloured Pencil, Biro - Any Subject.

### **6 - 10 YEARS**

**Entry Fee:** \$1

**Prize:** 1st - \$12, 2nd - \$8, 3rd - \$5

Class 25015 Oil, Watercolour, Acrylic

Any Subject

Class 25016 Drawing

Pencil, Felt Pen, Crayon, Coloured Pencil, Biro - Any Subject

**Requirements for the below classes age groups 11-13 Years, and 14 to Under 18 Years:**

1. Canvas and Framed Exhibits (securely wired ready for hanging) are accepted in this age group only.
2. Maximum size is 60cm x 60cm. Exhibits over this size are not accepted.
3. Students can present their work unframed and mounted on A4 card stock (21cm x 30cm).
4. Limit One (1) Entry per artist, per class.

### **11 - 13 YEARS**

**Entry Fee:** \$1

**Prize:** 1st - \$15, 2nd - \$12, 3rd - \$8

Class 25017 Oil, Watercolour, Acrylic

Any Subject

Class 25018 Drawing

Pencil, Felt Pen, Crayon, Coloured Pencil, Biro - Any Subject

Class 25019 Mixed Media & Printmaking

Any Subject

## JUNIOR ART – CONTINUED

### **14 - UNDER 18 YEARS**

**Entry Fee:** \$1

**Prize:** 1st - \$18, 2nd - \$15, 3rd - \$12

Class 25020 Oil, Watercolour, Acrylic

Any Subject

Class 25021 Drawing

Pencil, Felt Pen, Crayon, Coloured Pencil, Biro - Any Subject

Class 25022 Mixed Media & Printmaking

Any Subject

### **CHAMPION JUNIOR ARTWORK OF SHOW - \$25**

**Prize:** \$25 + Sash

## SPECIAL NEEDS

### **Requirements for the below classes:**

1. Canvas and frame exhibits (securely wired ready for hanging) are accepted in special needs.
2. Maximum size is 60cm x 40cm. Exhibits over this size are not accepted.
3. Artists can also present their work unframed and mounted on A4 card stock (21cm x 30cm).
4. Limit One (1) Entry per artist, per class.

**Entry Fee:** \$1

**Prize:** 1st - \$18, 2nd - \$15, 3rd - \$12

Class 25023 Oil, Watercolour, Acrylic

Any Subject

Class 25024 Drawing

Pencil, Felt Pen, Crayon, Coloured Pencil, Biro - Any Subject







**CAIRNS  
SHOW**



**16TH - 18TH  
JULY 2025**

**SECTION 26  
PHOTOGRAPHY**

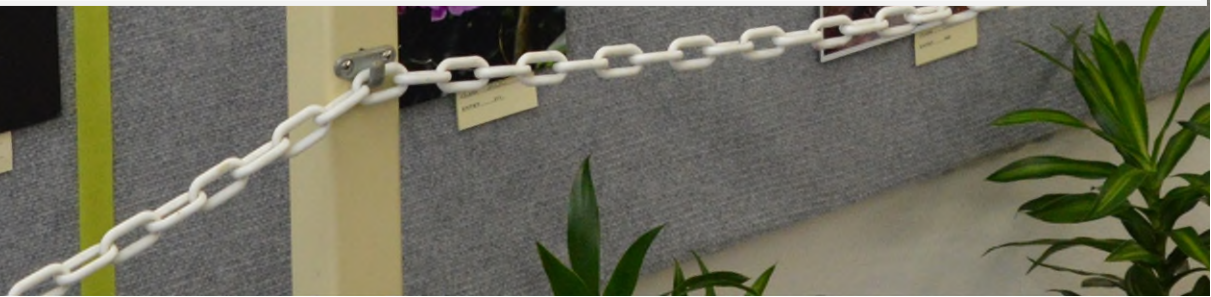
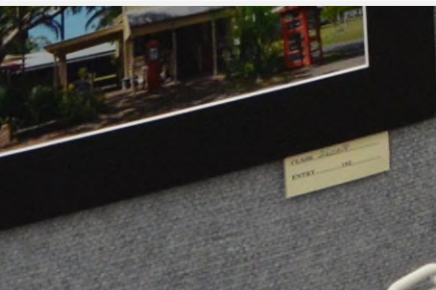

## SECTION 26 PHOTOGRAPHY

### OFFICIALS

Chief Steward: Richard Foord

Stewards: Members of the Cairns Photographic Society Inc.

### KEY INFORMATION

**Entry Fee:** \$5.00 for Open Classes, Free for Junior Classes.

**Prize:** As Stated in Schedule.

**Entries Close:** 4pm Friday 20th June.

**Delivery of Exhibits:** 12pm - 6pm Wednesday 9th July - back of Dave Headrick Grandstand.

**Judging:** 10am - 4pm Sunday 13th July.

**Exhibit Collection:** 9am - 11am Saturday 19th July - back of Dave Headrick Grandstand.

### SPONSORS

The Cairns Show Association wishes to record its sincere appreciation to the following Sponsors who have contributed to this area.

**Cairns Photographic Society, and Garrick's Camera House**

### DELIVERING THE PRINTS

1. Mounting and presentation of your photos form an important part of the judging.
2. Exhibits must be delivered to the Photography Room in the Dave Headrick Grandstand by the due time and date shown.
3. Whoever delivers your images must also present a copy of your entry receipt (printed or digital) at this time.
4. All entries must be presented fully mounted and ready for hanging. Any images that are not ready to be hung may be rejected.
5. Follow the details on sizing, mounting, display and labelling images in the Special Regulations set below.
6. Results will be published after the Show has concluded on the website.

### AFTER THE SHOW

1. All prints should be collected from the Dave Headrick Grandstand on Saturday 19th July between 9am and 11am.
2. If it is not possible to collect the prints on the Saturday, prints can be collected at the Cairns Show Office from Tuesday 22nd July. Prints not collected by 29th August 2025 will automatically become the property of the Cairns Show Association.
3. Prize Money can be collected between 9am and 4pm Monday to Friday 4th August to 29th August from the Show Office if your total prize money is less than \$50.
4. Proof of identity is required to collect Prize Money. If you are collecting prize money on behalf of someone else, a letter of authorisation from that person will be required.
5. All Prize Money less than \$50 not collected by 29th August, 4pm will be returned to the Cairns Show Association Funds.
6. Prize money of \$50 and over will be deposited to the entrant's nominated bank account after 29th August.
7. No Free passes are available to entrants.

## SPECIAL REGULATIONS

### PLEASE REFER TO GENERAL CONDITIONS OF ENTRY & COMPETITION IN FRONT OF ARTS & CRAFTS SCHEDULE FOR OVERRIDING CONDITIONS

#### IMAGE SOURCE AND EDITING

1. All images must be the original unaided work of the entrant (Commercial processing of the physical print is accepted in all classes).
2. There is no limit on the date the photograph was taken.
3. An image that has won a prize in previous Cairns Shows is not eligible for entry.
4. The image may be taken with any camera, drone, phone or tablet camera.
5. All images and image components used in the Creative / Experimental and Special Subject Theme classes must be created and owned by the entrant
6. **Editing of images**
  - Editing of images using photographic software such as Photoshop, Lightroom, Luminar and phone filters etc. is permitted to enhance the image to achieve the photographer's vision. (All classes)
  - Each image must be of a single image and may be treated with HDR, focus stacking, exposure bracketing, long exposure techniques, in-camera multiple exposure, but not by the merging of layers containing the same image taken at significantly different times. (All classes except Creative/Experimental, Open Special Theme and Junior Special Subject)
  - The elimination of objects through cloning or healing is accepted, and the use of "content-aware" fill technology is permitted where the fill content directly blends with the image and does not add additional elements not originally present in the image. (All classes)
7. **The addition of elements from third party sources is not permitted including (all classes):**
  - Components and images generated by AI or similar tools or technology.
  - Elements sourced from third party sources such as stock photography, internet sites etc.
  - Non-photographic elements such as graphics, text or clip art etc.
  - Specific digital drawing elements (note that techniques such as custom 'brushes' can be used).

#### ENTRY LIMITATIONS AND CLASSES

1. Class definitions and guidelines are important so should be read carefully
2. Maximum of 10 (ten) images per entrant with a limit of 3 (three) images per entrant for the junior section.
3. An image can only be entered in one class.
4. Junior entrants may enter images in both sections
  - Any image can only be entered into one class regardless of section.
  - Are limited to the total of 10 (ten) entries overall with a maximum of 3 (three) of these in the junior section.
5. At the discretion of the Chief Steward, an image may be moved out of one category into another, if deemed to be an incorrect fit for the entered category.
6. Entries must not include any watermarks, signatures, logos, advertising, web addresses, entrant's name etc. on the displayed image or front mounting materials.

## SPECIAL REGULATIONS – CONTINUED

### PRESENTATION AND MOUNTING

1. Mounting and presentation of your photos form an important part of the judging.
2. Mattes and frames can be any colour, but generally black mattes / mounts for this type of competition are best.
3. Images must be mounted on heavy stiff cardboard that does not bend easily or foam-core board. Other mounting materials including, but not limited to, acrylic, glass, wood, canvas or metal are not permitted.
4. Image thickness should not exceed 5mm.
5. There MUST be at least 4 velcro dots (HOOK side) on each corner of the back of the mounting frame.
6. Images may be double-mounted. That is, the image mounted on the backing as described earlier, with a cardboard frame (“mat”) over the top of the image fixed to the backing to help accentuate / frame the image.
7. Commercial services may be used to create the print and mount.
8. Write your Class Entered, Name, Entry Number and an Image Title on the back of the image. The image title can be descriptive (i.e. Purple Flower) or subjective (i.e. Bloom of Life)
9. All Junior Section entries must also include the Entrant’s School on the back of the image. This is important as prizes also go to schools as well as the entrant for the Junior Section
10. Class Cards will be provided and attached to the image when you deliver your image to the show grounds.

### IMAGE SIZES

#### **1. Open Section**

- The final image plus it’s mount must fit within a 41cm x 30.5cm (16”x12”) area.
- Therefore, if you have a square image, it may not be larger than 30.5cm x 30.5cm (12”x12”). An A3 piece of paper is 42cm x 29.7cm for reference.
- The actual image must not be smaller than 20cm x 15cm (8”x6”). Therefore, if you have a square image, it must be at least 8”x8”.
- The image plus its mount is not smaller than 25cm x 20cm (10”x8”).  
(This means if your image is the smallest possible size, you must have a border/mat of at least 2.5cm thickness around the edge).

#### **2. Junior Section**

- The maximum size of an entry, the image and any included “framing”, must not exceed 25cm x 20cm. The image may occupy this entire size pasted on to the required mounting material. An A4 piece of paper is 29.7cm x 21cm for reference.
- The size of each image must not be smaller than 15cm x 10cm (6”x4”).

## CLASS DEFINITIONS

### PEOPLE/PORTRAITURE:

- A Photograph of a person or persons that may range from a head study to full body length. This section includes candid photographs and formal portraits. This category is for photographs where people are the focus whether a single person or a group, showing the human aspect of life in all its wonderful variety. From self-portraits as an expression of the photographer, or portrait images capturing the personality of a person or group of people interacting. Images from events where the interaction of the people is central, or street and ad-hoc portraiture which capture the essence of lifestyle, random moments, real life, chance encounters.
- The person/people/interaction is central to the subject, not the activity or surroundings.

### SCAPES:

- In the monochrome section there is a single class combining both styles of images described below.
- Landscape and seascape photography is capturing an image that embodies the spirit of the outdoors. It carries a sense of being there to see something incredible. The image may contain people or man-made objects that provide perspective or highlight the grandeur of the landscape. These man-made elements may also balance the image or enhance the sense of calm, danger, action, isolation etc. of the landscape while remaining incidental to the core story.
- Urban and streetscape photography records the true state of the human condition by showing how society acts when it thinks that nobody is watching. Streetscapes can show the harsh geometry of man-made structures AND/OR contrast them around contradictory natural objects. They will often show the intense crowding of high-density living or the desolation of abandoned or empty streets. They include shapes, patterns, reflections found commonly in the man-made world and the actions and interactions of life and living in an environment that is distinctly human made and both positive and negative sides of the human-urban condition. Streetscapes may often include people and man-made objects where the focus is the scape and the urban environment over the individuals or the activity inside the scape.
- Close-up features are NOT regarded as landscapes.

### ACTION / SPORTS:

- Images that emphasise sports or personal pursuits that involve and portray a high energy environment. They can show a moment in time, a particular active event or portray the artistry / symmetry of moment in time of participation. These shots either catch a clear frozen moment, or rather imply the blur of rapid movement. The viewer is clearly in awe of activity and the participant.
- The Natural Kingdom:
- Includes birds, insects, animals, reptiles and fishes and including animals of a domestic nature provided no evidence of restrictions or caging or fencing is evident.
- This includes plants and/or flowers through any stage of the life cycle, from seed to decay. This includes bark, leaves, fungi, as well as flowers, seeds and grasses. Subjects may be cultivated or uncultivated.

### SPECIAL TECHNIQUE – AERIAL PHOTOGRAPHY:

- This class will change from year to year. For 2024 this is an opportunity to showcase images taken from the air.
- Aerial images provide a unique perspective – usually of the natural world highlighting patterns not visible when standing on the land. Images can be a simple shot out an airplane window, or a helicopter shot, or taken from a drone (including “stitched” aerial panoramas)

## CLASS DEFINITIONS – CONTINUED

### SPECIAL SUBJECT THEME – DOORS AND WINDOWS:

- This class is a subjective theme that will change from year to year.
- The theme may be taken literally OR may also be taken figuratively.
- For 2024 the theme of Doors and Windows can be explored showing simple doors and windows or an artistic subjective view of what doors or windows represent to society.
- It may also be a simple image comparing multiple doors and images across cultures, times, architectures etc.
- This class can include creative editing techniques and such as composite editing similar to that allowed in Creative / Experimental where the outcome represents the subject in the eyes of the judges. Following all the requirements of a creative section – all components must be the work of the entrant.

### CREATIVE / EXPERIMENTAL:

- Creative or experimental photographs display a novel effect because of an unusual combination of objects and/or unusual viewpoint. Images may consist of composite of multiple photographs and that have been modified during or after exposure.
- Images may also include the use of an elaborate set or make-up to portray a surreal or unreal situation. Resulting images may be the result of combining multiple images taken by the photographer. Creativity and innovation in the construction of the image and its elements may include editing through the use of software or the mere application of creative studio lighting or in camera techniques.
- All components of the image must be the property of the photographer.
- Creative or experimental photographs may be Colour or Monochrome.

### OPEN:

- Any subject created pictorially where the image has the key elements of design, arrangement, composition and wow.
- A reflection of the photographer's interpretation and can include direct or abstract concepts, minimalism, shape studies etc.

### JUNIOR CLASSES:

- Junior Classes for '12 Years of Age and Under - Open - Any Subject', and '13 Years to Under 18 Years - Open - Any Subject' should follow the guidelines above for "Open" with editing allowed as per the guidelines under Image Source and Editing.
- The Junior Special Subject class can follow the extended editing outlines available to Creative/Experimental as noted above. Taking note of not adding components, into the final image, that are not created by the entrant, come from the general internet, general web picture or tool libraries or generated by AI tools.



The **Cairns Photographic Society** is our community's gateway to a broad range of photography skills and resources. Members have access to meetings, outings, free and subsidised learning and special photo events and accredited judges' advice and critique of images. Contact us for information. [cairnsphtosociety@gmail.com](mailto:cairnsphtosociety@gmail.com)



## OPEN SECTION - MONOCHROME

**Entry Fee:** \$5.00

**Prize:** 1st - \$40.00, 2nd - \$20.00, 3rd - \$10.00

**Any photograph containing shades of only one colour. If toning is carried out, it must be over the total photograph. Any image containing partial toning and/or the addition of one extra colour is not acceptable in a monochrome class.**

**Any image determined to not meet the definition of monochrome may be moved to a corresponding class in the Colour and Combined section at the discretion of the Chief Steward.**

Class 26001 Monochrome - People

Class 26002 Monochrome - Scapes

Class 26003 Monochrome - Open

### CHAMPION MONOCHROME PRINT

**Prize:** Battery World Perpetual Trophy + Sash

## OPEN SECTION – COLOUR & COMBINED

**Entry Fee:** \$5.00

**Prize:** 1st - \$40.00, 2nd - \$20.00, 3rd - \$10.00

**All classes in this section may contain full colour OR monochrome images. At the discretion of the Chief Steward a monochrome image that is submitted in a class may be moved to the specific monochrome section where this is more applicable.**

**Any image presented in this section that is rendered in Monochrome will still be considered to be eligible for the Champion Monochrome Print.**

Class 26004 Colour - People

Class 26005 Colour - Land & Sea Scapes

Class 26006 Colour - Urban & Street Scapes

Class 26007 Action / Sports

Class 26008 The Natural Kingdom

Class 26010 Special Theme - Doors & Windows

Class 26009 Special Technique - Aerial

Class 26011 Open

Class 26012 Creative / Experimental

### CHAMPION COLOUR PRINT

**Prize:** Dawsons Engineering Perpetual Trophy + Sash

### GRAND CHAMPION IMAGE OF SHOW - \$350

**Selected by judges between Champion Colour Print & Champion Monochrome Print**

**Prize:** The Cairns Photographic Society Inc Perpetual Trophy + Sash

### RESERVE GRAND CHAMPION IMAGE OF SHOW - \$150

**Selected by judges between Champion Colour Print & Champion Monochrome Print**

**Prize:** Sash

**OPEN SECTION – COLOUR & COMBINED – CONTINUED****CHAMPION PHOTOGRAPHER OF SHOW**

**Awarded to the Exhibitor who gains the most Aggregate Points, overall in the Photography Section**

**Prize:** The Cairns Photographic Society Inc Perpetual Trophy + Sash

**Points awarded as follows:**

For each Open Class: **First** - 3 points, **Second** - 2 points, **Third** - 1 point.

Champion Monochrome Print, Champion Colour Print: 5 points

**JUNIOR SECTION**

**Entry Fee:** FREE

**All Classes Prizes:** 1st - \$30 + Ribbon, 2nd - \$15 + Ribbon, 3rd - \$10 + Ribbon

Class 26013 12 Years of Age and Under - Open - Any Subject

**SCHOOL AWARD – FIRST PLACE STUDENT – 12 YEARS AND UNDER - \$200**

**Awarded to the nominated school of the student with the first-placed print**

Class 26014 13 Years to Under 18 Years - Open - Any Subject

**SCHOOL AWARD - FIRST PLACE STUDENT - 13 YEAR TO UNDER 18 YEARS - \$200**

**Awarded to the nominated school of the student with the first-placed print**

Class 26015 Special Subject: My Tropical Home - Open All Ages Under 18 Years

**This class is open to All Ages in the Junior Section (under 18 years old)**

Create an image that you believe encapsulates both the sense of Home as well as The Tropics and/or our Tropical Surroundings or Climate. Cairns is a beautiful location and the rugged beauty of the gulf to the Torres Strait islands as well as the temperature, storms and humidity all play a factor in defining our home lives in the tropical climate and can result in some wonderful displays of home life in the North.

**GARRICK'S CAMERA HOUSE AWARD**

**Awarded to the individual of First Placed Print in the Junior Open Class – Class 26015**

**Prize:** Garricks Camera House 18" x 24" Canvas Print Voucher

The logo for CameraHouse, featuring the word "CameraHouse" in a bold, sans-serif font. The "C" is significantly larger than the other letters. A small red dot is positioned above the "e" in "House".





**CAIRNS  
SHOW**

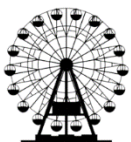

**16TH - 18TH  
JULY 2025**

**SECTION 27  
CRAFT &  
NEEDLEWORK**

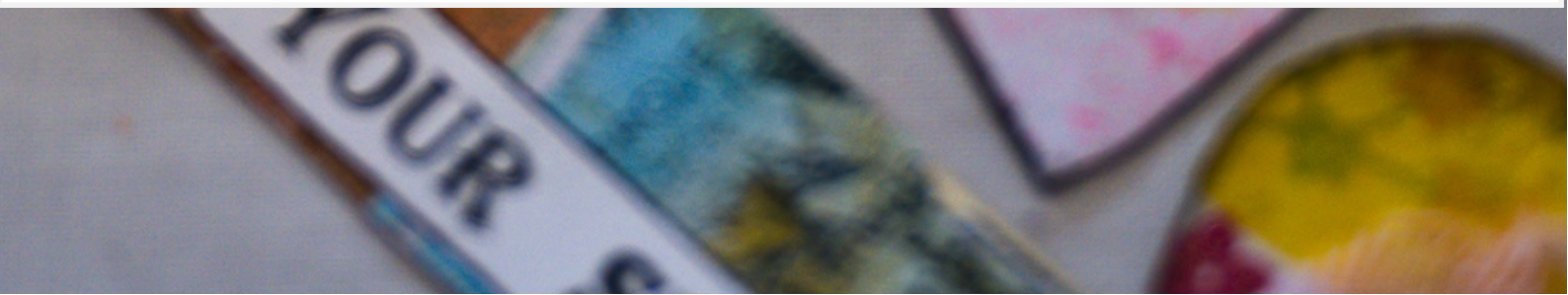

## SECTION 27 CRAFT & NEEDLEWORK

### OFFICIALS

Chief Steward: Ms. Carol Coates

Steward: Mrs. Jan Anderson, MS. Mary Mattson, Mrs. Chris Osborne, and Mrs. Sandra Bawden.

### KEY INFORMATION

**Entry Fee:** FREE

**Prize:** 1st - \$8 + Card, 2nd - \$4 + Card, 3rd - Card, Highly Commended Card - *unless otherwise stated*

**Entries Close:** 4pm Friday 20th June. Entries on the day of Delivery may be accepted.

**Delivery of Exhibits:** 9am-4pm Thursday 10th July and Friday 11th July - WIN News Arts & Crafts Pavilion (underneath De Jarlais Function Centre). Lapidary must be taken to the Fred Moule Exhibition Centre (refer to Sub Section for notes).

**Judging:** 9am Saturday 12th July.

**Collection of Exhibits:** 10am-2pm Saturday 19th July - Main Arena (Centre Ring) side of Arts & Crafts Hall.

### SPONSORS

The Cairns Show Association wishes to record its sincere appreciation to the following Sponsors who have contributed to this area.

**Channel 9 WIN News, and Showbag Warehouse.**

### HOW TO ENTER

1. Complete an Entry online or in person at the Cairns Show Office, or post via PO Box 811 Bungalow, QLD 4870.
2. Entries will not be accepted over the phone. Entries may be accepted on the day of Delivery.
3. Entries must be delivered to the designated part of the Showgrounds by the due date time and date shown.

### AFTER THE SHOW

1. Exhibits NOT collected by Friday 29th August 2025 will become Property of the Cairns Show Association.
2. Prize Money can be collected between 9am and 4pm Monday to Friday 4th August to 29th August from the Show Office if your total prize money is less than \$50.
3. Proof of identity is required to collect Prize Money. If you are collecting prize money on behalf of someone else, a letter of authorisation from that person will be required.
4. All Prize Money less than \$50 not collected by 29th August, 4pm will be returned to the Cairns Show Association Funds.
5. Prize money of \$50 and over will be deposited to the entrant's nominated bank account after 29th August. Please ensure you have provided your bank details to the Cairns Show Office. If you have not, a staff member will contact you via email.
6. Results will be available from the [Cairns Show website](#) AFTER the conclusion of the Show.

## SPECIAL REGULATIONS

### PLEASE READ SPECIAL REGULATIONS FOR THE CLASS YOU ARE ENTERING THOROUGHLY

1. Refer General Conditions of Entry and Competition in the front of this Schedule.
2. All exhibits must be the original and unaided work of the exhibitor. Factory made articles are not allowed in this Section.
3. No exhibit can be entered into more than one class.
4. All exhibits in Junior Classes must be nominated under their name, signed by an adult and include date of birth on entry form.
5. All exhibits must have been executed/completed within the last twelve (12) months prior to the 2025 Cairns Show.
6. To assist the Stewards in arranging and dispatching exhibits after the Show, a sealed envelope containing name and address of owner must be securely attached to the back of each exhibit.
7. Please attach Class Card to the back, bottom right-hand corner of the exhibit, the class card must be visible.
8. Name and address or contact number must also be on the back of the Class Card.
9. All exhibits forwarded by mail must include return postage. The Cairns Show Association takes absolutely no responsibility for items forwarded by mail.
10. No person other than Judges, Chief Steward and Stewards to be present while Judging is taking place. Arts & Crafts Pavilion will be locked during Judging.
11. The Judge reserves the right to alter the Class of an exhibit.
12. Out of town exhibitors may collect exhibits AFTER the fireworks for 30 minutes on Friday Night 18th July 2025. Prior arrangements must be made with the Chief Steward.
13. In the event of an exhibit in any one class not being worthy of a prize, no prize money will be awarded.
14. Please deliver items between 9am - 4pm on Thursday 10th and Friday 11th July 2025.
15. Exhibits may be collected from 10am to 2pm Saturday 19th July 2025 from The Arts and Crafts Hall - Ring Side (underneath the De Jarlais Function Centre at the Showgrounds).
16. No responsibility will be taken for exhibits left in the Arts & Crafts Hall after this time.
17. No free passes available to exhibitors.
18. All exhibits in the Craft Classes should be suitably framed and wired ready for hanging otherwise they will not be hung.
19. All exhibits for sale must be clearly marked with price. Exhibits not for sale must be marked "NFS".
20. Commission of 20% will apply to all works sold and must be included in the sale price. Please liaise with Chief Steward.
21. Sold exhibits must not be removed until Saturday 19th July 2025.
22. Please ensure you are aware of your class number. This is the number on the far-left hand side of the class description in Schedule.
23. Translation card (if necessary) attached to item on the right-hand corner at the front.

## CRAFT

### **OPEN CRAFT**

Class 27001 Thrift Article

**Made from scrap material - any medium**

Class 27002 Any Upcycled Article

**Any medium - Paper, Metal, Wood, Fabric. Description to be included.**

Class 27003 Woodburning

Class 27004 Novelty Article

Class 27005 2 Coat Hangers

**Any medium - 2 distinctive patterns.**

Class 27006 Toy

**Any medium - not knitted or crocheted.**

Class 27007 Macrame

Class 27008 Beadwork - Jewellery

Class 27009 Beadwork - Any Other Article

Class 27010 Glass

**Example: beads, slumped glass, etc.**

Class 27011 Mosaic - 2 Dimensional

Class 27012 Mosaic - 3 Dimensional

Class 27013 Dressed Doll

Class 27014 Scrapbooking - Category 'Christmas'

**Open Class - One page, in plastic sleeve.**

Class 27015 Scrapbooking - Category 'Celebration of Anything'

**Open Class - One page in plastic sleeve.**

Class 27016 Scrapbooking - Category 'Heritage'

**Open Class - One page in Plastic Sleeve**

Class 27017 Paper Crafting Card

**For any Occasion and Technique**

Class 27018 Paper Crafting Technique

**Handmade Books, Altered Books and Paper Tole**

Class 27019 Christmas Decoration - Any Article

Class 27020 Millinery

**Any medium, any style.**

Class 27021 Resin Work

Class 27022 Any Other Article Not Mentioned

### **COMBINATION CRAFT**

Class 27023 Any Article

**Open Class - Wood metal, wire, mixed media, crochet/knitting, sewing/dying - Be creative**

Class 27024 Group Projects

**5 people or more**

## CRAFT – CONTINUED

### HAND DRAWN ART

Created Using Repetitive Patterns (Tangles)

#### **SPECIAL REGULATIONS**

1. Min Size: Greeting Card
2. Max Size: A4
3. No signatures on front of artwork

Class 27025 Abstract Repetitive Patterns (Tangles)

**Viewed from any orientation. Black, white with grey shading palette only.**

Class 27026 Traditional Art or Structured

**Designed together with Repetitive Patterns (Tangles). Viewed from a specific oriental. Any colour palette.**

### **CHAMPION OPEN CRAFT OF SHOW - \$20**

**Open to Classes 27001 - 27026**

**Prize: \$20 + Sash**

### FOLK ART

**All Folk Art exhibits must comply with the Conditions of Entry.**

Class 27027 Folk Art – Junior

**For children Under 15 Years. MUST have been completed in a classroom situation and must be the unaided work of the exhibitor.**

Class 27028 Folk Art – Beginners

**Less than 2 Years experience**

Class 27029 Folk Art – Intermediate

**Over 2 Years experience**

Class 27030 Folk Art – Open Traditional

**Baroque, Bauernmaleri Hinderloopen, Intarsia, Naïve, Rosemailing, Russian Floral.**

Class 27031 Folk Art – Open Decorative

**Floral and other themes, boats, fairies, lace, teddies, etc.**

### **CHAMPION FOLK ART OF SHOW - \$20**

**Open to Classes 27028 - 27032**

**Prize: \$20 + Sash**

### JUNIOR CRAFT - 12 YEARS AND UNDER

**Prize: 1st - \$5, 2nd - \$3, 3rd - \$2, Highly Commended Card.**

Class 27032 Beadwork

**Any Article**

Class 27033 Novelty - Made from Paper Plate

Class 27034 Christmas Decoration

**Hanging Christmas Tree Decoration or Christmas Table Decoration**

Class 27035 French Knitting

**Any Article**

Class 27036 Toy

**Any Article**

Class 27037 Paddle Pop Sticks

**Any Article**

## CRAFT – CONTINUED

Class 27038 Paper Mache

**Any Article**

Class 27039 Scrapbooking

**Junior Class - Any Category, One Page, in Plastic Sleeve.**

Class 27040 Loom Craft

Class 27041 Any Other Article Not Mentioned

Class 27042 Paper Crafting Card

**Card for any Occasion and Technique.**

Class 27043 Any Machine Sewn Article or Clothing

Class 27044 Two Coat Hangers

**Any Medium**

**CHAMPION JUNIOR CRAFT 12 YEARS AND UNDER OF SHOW - \$20**

**Prize: \$20 + Sash**

**JUNIOR CRAFT - 13 YEARS TO UNDER 18 YEARS**

**Prize: 1st - \$5, 2nd - \$3, 3rd - \$2, Highly Commended Card.**

Class 27045 Beadwork

**Any Article**

Class 27046 Novelty Made from Paper Plate

Class 27047 Christmas Decoration

**Hanging Christmas Tree Decoration or Christmas Table Decoration.**

Class 27048 French Knitting

**Any Article**

Class 27049 Toy

**Any Article**

Class 27050 Paddle Pop Sticks

**Any Article**

Class 27051 Paper Mache

**Any Article**

Class 27052 Scrapbooking

**Junior Class - Any Category, One Page, in plastic sleeve.**

Class 27053 Loom Craft

Class 27054 Any Other Article Not Mentioned

Class 27055 Paper Crafting Card

**For any Occasion and Technique**

Class 27056 Any Machine Sewn Article or Clothing

Class 27057 Two Coat Hangers

**Any Medium**

**CHAMPION JUNIOR CRAFT 13 YEARS TO UNDER 18 YEARS OF SHOW - \$20**

**Prize: \$20 + Sash**

## NEEDLEWORK

### KEY INFORMATION

**Entry Fee:** FREE

**Prize:** 1st - \$8 + Card, 2nd - \$4 + Card, 3rd - Card, Highly Commended Card - *unless otherwise stated*

### SPECIAL REGULATIONS

1. Exhibits must not be washed but should be well pressed. Cleanliness is essential to hand work.
2. All exhibits must have been executed/completed within the last twelve (12) months prior to the 2025 Cairns Show.

### OPEN CROCHET

Class 27058 Infant's Bonnet or Booties

Class 27059 Baby's Outfit

**Not less than 3 pieces (a pair of Bootees is classed as 1 piece).**

Class 27060 Doyley

**Up to 21 cm**

Class 27061 Table Centre

**Over 21cm**

Class 27062 Runner or Tray Cloth

Class 27063 Handkerchief

Class 27064 Lady's Stole or Shawl

**Any Medium**

Class 27065 Tea Cosy

**Any Medium**

Class 27066 Cushion

**Any Medium**

Class 27067 Toy

**Any Medium**

Class 27068 Bedspread or Knee Rug

**Any Medium**

Class 27069 Fridge Towel

Class 27070 Any Other Article Not Specified

### CHAMPION CROCHET OF SHOW - \$20

**Prize:** \$20 + Sash

### OPEN HAND KNITTING

Class 27071 Infant's Bonnet or Booties

Class 27072 Baby's Outfit

**Not Less Than 4 Pieces (a pair of booties is classed as 1 piece).**

Class 27073 Adults Pullover, Vest, Cardigan or Garment

Class 27074 Toy

Class 27075 Tea Cosy

Class 27076 Any Other Knitted Article Not Specified

### CHAMPION OPEN HAND KNITTING OF SHOW - \$20

**Prize:** \$20 + Sash

## NEEDLEWORK – CONTINUED

### **MACHINE KNITTING**

Class 27077 Machine Knitting Novice

Class 27078 Machine Knitting Open

### **CHAMPION MACHINE KNITTING NOVICE**

**Less than twelve months experience**

**Prize:** Sash

### **CHAMPION MACHINE KNITTING OPEN**

**Prize:** Sash

### **OPEN HAND EMBROIDERY**

Class 27079 Smocked

**Any Article. Smocking - 90% Judging 10% Finishing of Article**

Class 27080 Applique Work

Class 27081 Table Centre

Class 27082 Cross Stitch Picture Framed

Class 27083 Cross Stitch and Embellishments

Class 27084 Cross Stitch - Any Other Article Not Mentioned

Class 27085 Needlework Picture Including Tapestry

**Must be Framed**

Class 27086 Tapestry Longstitch Picture

**Must be Framed**

Class 27087 Hardanger

**Any Article**

Class 27088 Runner or Tray Cloth

Class 27089 Doyleys

**3 Distinctive Patterns**

Class 27090 Hand Embroidery Traditional

Class 27091 Hand Embroidery Contemporary

Class 27092 Fabric Hand Stitched Book

**Journal may include some free Machine Embroidery. Any Article.**

Class 27093 Pin Cushion

**Any Medium**

### **CHAMPION OPEN HAND EMBROIDERY OF SHOW - \$20**

**Prize:** \$20 + Sash

### **BOBBIN LACE**

**Entry Fee:** FREE

**Prize Money:** 1st - \$50.00, 2nd - \$25.00, 3rd - \$10.00

Class 27094 Bobbin Lace

**Type of lace and designers name (or own design) to accompany exhibit.**

### **CHAMPION BOBBIN LACE OF SHOW**

**Prize:** Sash



## NEEDLEWORK – CONTINUED

### OPEN MACHINE SEWING

**Any item professionally quilted must be entered into the relevant section. Example: Patchwork, Applique etc. not into quilting.**

Class 27095 Embroidery

**Any Medium**

Class 27096 Applique Work

Class 27097 Quilting

**Any Article**

Class 27098 Art Quilt

Class 27099 Child's Garment

Class 27100 Evening Wear

Class 27101 Garment

Class 27102 Decorated Hand Towel and Washer Set

Class 27103 Apron

Class 27104 Patchwork

Class 27105 Bag

**Any Medium**

Class 27106 Cushion

**Any Medium**

Class 27107 Machine Sewing

**Minimum of 3 Machine Sewing techniques - Any Article.**

For example: Patchwork, Quilting, Applique or Machine embroidery. Please provide description of how item was made and what techniques were used. Can include dying and hand embroidery but must have a minimum of 3 Machine Sewing techniques.

Class 27108 Any Other Machine-Made Article Not Specified

**Example: printed panel with minimum outline quilting**

### CHAMPION MACHINE SEWING OF SHOW - \$20

**Prize: \$20 + Sash**

### 70 YEARS AND OVER

Class 27109 Crochet

**Any Article**

Class 27110 Knitting

**Any Article**

Class 27111 Embroidery Work

**Any Article**

Class 27112 Novelty

**Any Article, including Fabric Books/Journals.**

Class 27113 Any Other Article Not Mentioned

Class 27114 Embroidery Work

**Free Motion Embroidery Work**

### CHAMPION 70 YEARS AND OVER

**Prize: Sash**

## NEEDLEWORK – CONTINUED

### **80 YEARS AND OVER**

Class 27115 Any Article

### **CHAMPION 80 YEARS AND OVER - \$25**

**Prize: \$25 + Sash – Sponsored by Vjay's Sewing Services**



### **JUNIOR - 12 YEARS OF AGE AND UNDER**

**State Age on Entry Form.**

**Prize: 1st - \$5 + Sash, 2nd - \$3, 3rd - \$2, Highly Commended Card**

Class 27116 Crochet

**Any Article**

Class 27117 Knitting

**Any Article**

Class 27118 Embroidery

**Any Article**

Class 27119 Novelty Garment

**Machine Sewing**

Class 27120 Patchwork Bag

Class 27121 Cushion

**Machine Sewing**

Class 27122 Toy

**Any Medium**

Class 27123 Dressed Doll

Class 27124 Two Coat Hangers

**Any Medium**

Class 27125 Pin Cushion

**Any Medium**

Class 27126 Any Article Not Specified

### **JUNIOR - 13 YEARS TO UNDER 18 YEARS OF AGE**

**State Age on Entry Form**

**Prize: 1st - \$5 + Sash, 2nd - \$3, 3rd - \$2, Highly Commended Card**

Class 27127 Crochet

**Any Article**

Class 27128 Knitting

**Any Article**

Class 27129 Embroidery Work

**Any Article**

Class 27130 Garment

**Machine Sewing**

Class 27131 Nightwear

**Machine Sewing**

Class 27132 Tea Cosy

**Any Medium**

Class 27133 Table Centre

**Any Medium**

Class 27134 Toy

**Any Medium**

## NEEDLEWORK – CONTINUED

Class 27135 Two Coat Hangers

**Any Medium**

Class 27136 Any Article Not Specified

Class 27137 Pin Cushion

**Any Medium**

### CHAMPION JUNIOR OF SHOW - \$20

**Prize:** \$20 + Sash – **Sponsored by Vjay's Sewing Services**



### SPECIAL NEEDS 12 YEARS AND UNDER

**State Age on Entry Form**

**Prize:** 1st - \$5 + Sash, 2nd - \$3, 3rd - \$2, Highly Commended Card

Class 27138 Crochet

**Any Article**

Class 27139 Knitting

**Any Article**

Class 27140 Embroidery Work

**Any Article**

Class 27141 Any Machine-Made Article

Class 27142 Any Craft Item

Class 27143 Any Other Painted Article

Class 27144 Any Article Not Specified

Class 27145 Pin Cushion

**Any Medium**

### CHAMPION SPECIAL NEEDS 12 YEARS AND UNDER

**Prize:** Sash

### SPECIAL NEEDS 13 YEARS TO UNDER 18 YEARS

**State Age on Entry Form**

**Prize:** 1st - \$5 + Sash, 2nd - \$3, 3rd - \$2, Highly Commended Card

Class 27146 Crochet

**Any Article**

Class 27147 Knitting

**Any Article**

Class 27148 Embroidery Work

**Any Article**

Class 27149 Any Machine-Made Article

Class 27150 Any Craft Item

Class 27151 Any Other Painted Article

Class 27152 Any Article Not Specified

Class 27153 Pin Cushion

**Any Medium**

### CHAMPION SPECIAL NEEDS 13 YEARS TO UNDER 18 YEARS

**Prize:** Sash

**NEEDLEWORK – CONTINUED****SPECIAL NEEDS - OPEN****State Age on Entry Form****Prize:** 1st - \$5 + Sash, 2nd - \$3, 3rd - \$2, Highly Commended Card

Class 27154 Crochet

**Any Article**

Class 27155 Knitting

**Any Article**

Class 27156 Embroidery Work

**Any Article**

Class 27157 Any Machine-Made Article

Class 27158 Any Craft Item

Class 27159 Any Other Painted Article

Class 27160 Any Article Not Specified

Class 27161 Pin Cushion

**Any Medium****CHAMPION SPECIAL NEEDS - OPEN****Prize:** Sash**GRAND CHAMPION NEEDLEWORK ARTICLE OF SHOW****Prize:** Sash**GRAND CHAMPION OF HALL****Prize:** Sash

## LAPIDARY

### KEY INFORMATION

**Entry Fee:** FREE - *limit of 2 entries per person, per class.*

**Prize:** 1st - \$8 + Card, 2nd - \$4 + Card, 3rd -Card, Highly Commended Card.

### Delivery of Exhibits:

1. All entries must be delivered by 10am 2<sup>nd</sup> June - Members of the Cairns Mineral & Lapidary Club must deliver their entries to the Club directly. Members of the Public must deliver their entries to the Cairns Show Office.
2. No late entries will be accepted.
3. All entries must be accompanied with the General Entry Form, or a copy of the Showday Online entries.
4. Entries may be posted to the Cairns Show Office by 3rd June. Please post to PO Box 811 Bungalow, QLD 4870.

**Judging:** 12pm Tuesday 16th July. Judge is an accredited Judge for QLD Lapidary & Allied Craft Clubs Association (QLACCA).

**Collection of Entries:** *To be confirmed.*

### CONDITIONS OF ENTRY

1. The competition is classed as a level two competition. This competition shall be run in accordance with the AFLACA Competition and Judging Manual Issue No.8, April 2015.
2. All possible care will be taken with entries, but the committee will not be held responsible for any loss or damage during display, storage, or transport. Insurance is the responsibility of the competitor.
3. All entries are to be the applicant's own work. No entry must have won at the same level, group, and division.

### NOVICE SECTION

Class 27162 N.16 Gem Tree

Class 27163 N.1A Standard Cabochon

**Minimum Size 29mm on Longest Axis. Any material - craftsmanship.**

Class 27164 N.8A Faceted Standard Round Brilliant with Continuous Girdle

**Minimum Size 8mm - Quartz**

Class 27165 N.18E Wire Wrapped Jewellery with Lapidary Item Cut and Set by Entrant

Class 27166 N.18D Hand Fabricated Jewellery with Commercial Lapidary Item/s

**Set by Entrant - Any material.**

Class 27167 N.20A Cast Jewellery Not Intended to Include Lapidary

### OPEN SECTION

Class 27168 O.1B Fancy Cabochon

**Any material - craftsmanship.**

Class 27169 O.9A Faceted Standard Oblong Step cut with Cut Corners Quartz.

Class 27170 O.18E Wire Wrapped Jewellery with Lapidary Item/s Cut and Set by Entrant

**Any material.**

Class 27171 O.18A Hand Fabricated Jewellery without Lapidary



## STANDARD OBLONG STEP CUT WITH CUT CORNERS

**Section O.9A Quartz** Facets 53: Meets 44 (Crown – 24, Pavilion – 20)  
 NOTE: Stone L/W ratio must generate an obvious 'keel'  
 Angles for R.I. = 1.540  
 45 + 8 girdles = 53 facets  
 2-fold, mirror-image symmetry  
 96 index  
 L/W & T/W = refer to step G2 U/W = 0.554  
 P/W = 0.656 C/W = 0.240  
 Vol./W<sup>3</sup> = refer to step G2

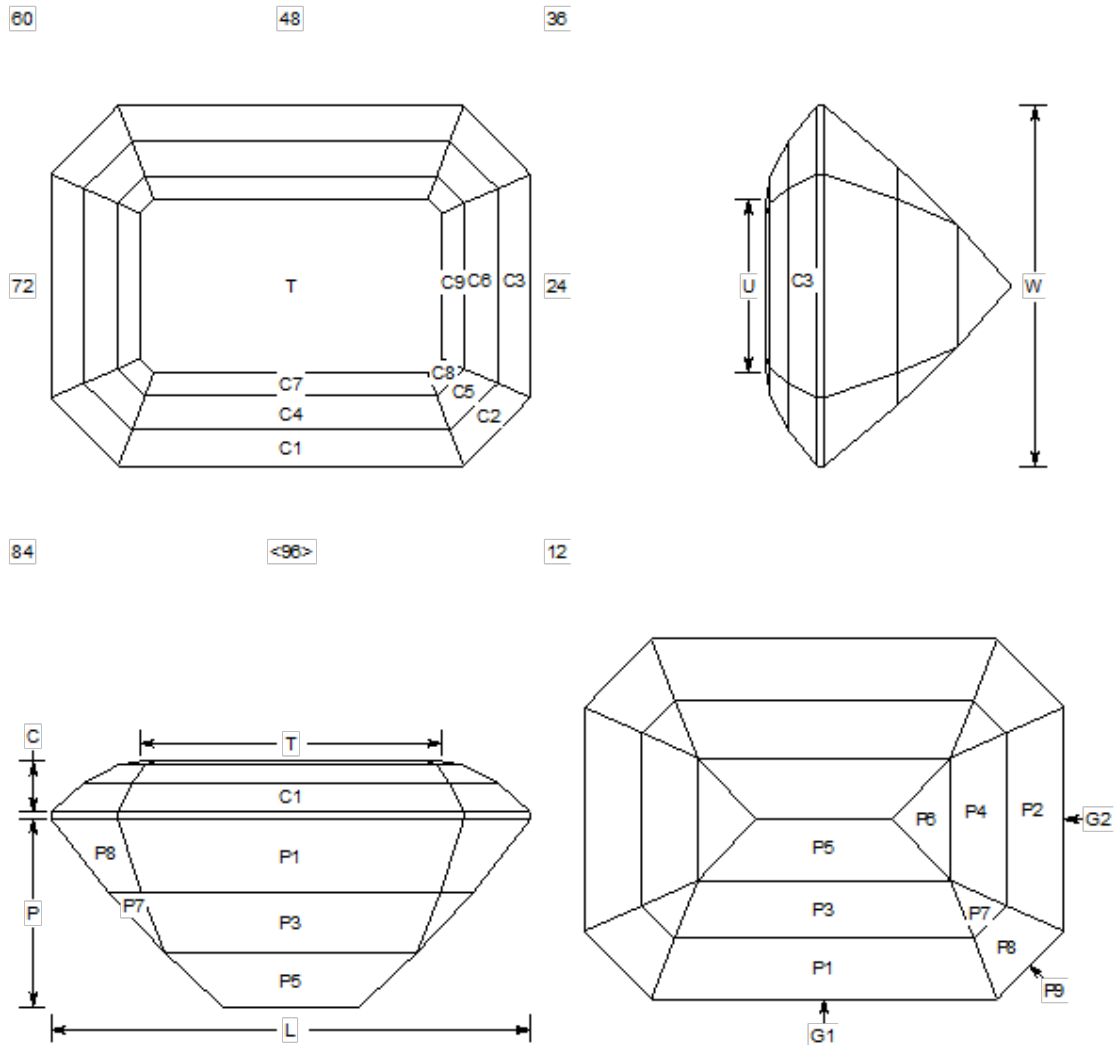

PAVILION			CROWN			
G1	90.00°	96-48	Set width	C1	55.00° 96-48	Set girdle thickness
G2	90.00°	24-72	Set length, see NOTE	C2	55.00° 12-36-60-84	Level girdle
P1	63.00°	96-48	Form girdle	C3	55.00° 24-72	Level girdle
P2	63.00°	24-72	Level girdle	C4	42.00° 96-48	Judge height by eye
P3	53.00°	96-48	Judge depth by eye	C5	42.00° 12-36-60-84	Meet C1-C2-C4
P4	53.00°	24-72	Meet P1-P2-P3	C6	42.00° 24-72	Meet C2-C3-C5
P5	43.00°	96-48	Judge depth by eye, form keel	C7	26.00° 96-48	Judge height by eye
P6	43.00°	24-72	Meet P3-P4-P5	C8	26.00° 12-36-60-84	Meet C4-C5-C7
P7	53.00°	12-36-60-84	Meet P3-P4-P5-P6	C9	26.00° 24-72	Meet C5-C6-C8
P8	63.00°	12-36-60-84	Meet P1-P3-P7	T	0.00° Table	Judge height by eye
P9	90.00°	12-36-60-84	Level girdle			

**STANDARD ROUND BRILLIANT WITH CONTINUOUS GIRDL**

**Section N.8A**

**Quartz**

Facets 58: Meets 41 (Crown – 24, Pavilion – 17)  
 Angles for R.I. = 1.540  
 57 + 1 rolled girdle = 58 facets  
 8-fold, mirror-image symmetry  
 96 index  
 L/W = 1.000 T/W = 0.556 U/W = 0.556  
 P/W = 0.450 C/W = 0.139  
 Vol./W<sup>3</sup> = 0.198

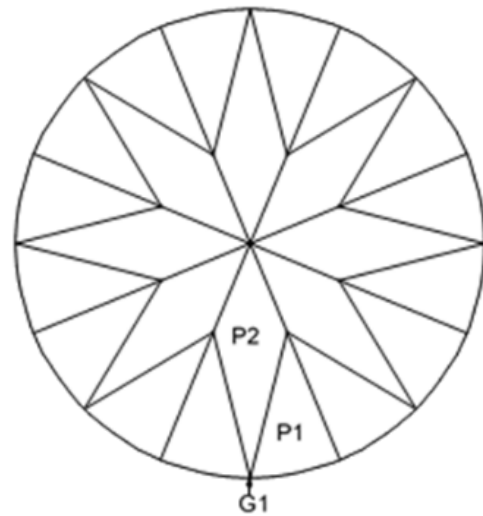
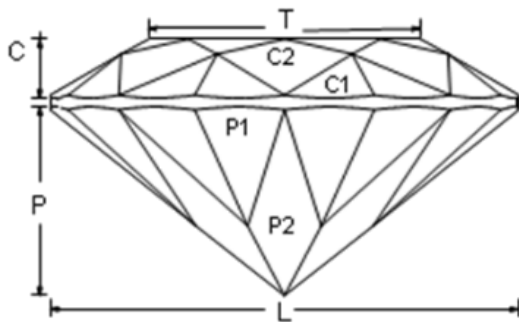
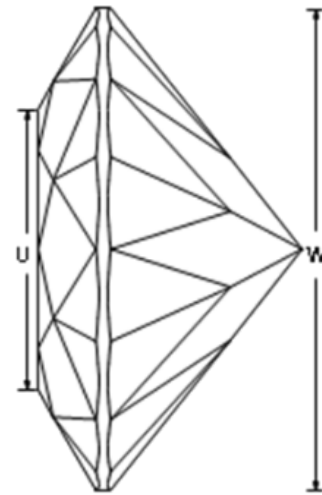
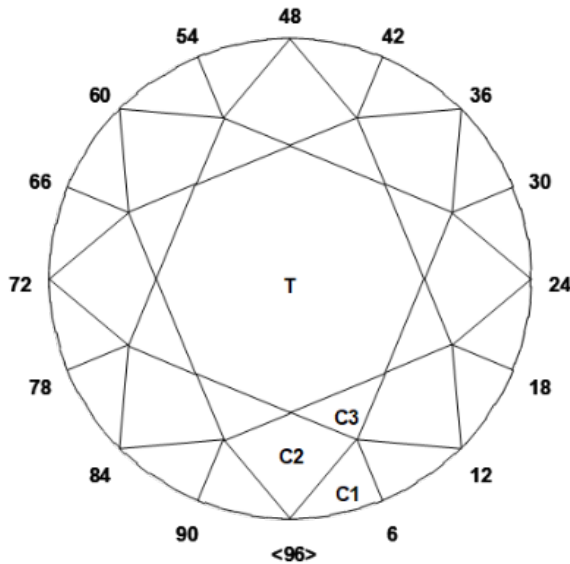

**PAVILION**

**CROWN**

03-09-15-21-27-33-39-45-51-57-63-69-75-81-87-93	Create TCP	C1	42.00 <sup>0</sup>	03-09-15-21-27-33-39-45-51-57-63-69-75-81-87-93	Set girdle thickness
Girdle	Cut to size, rolled girdle	C2	35.00 <sup>0</sup>	96-12-24-36-48-60-72-84	Meet C1, G
96-12-24-36-48-60-72-84	Meet P1, G, form PCP	C3	20.00 <sup>0</sup>	06-18-30-42-54-66-78-90	Meet C1, C2
		T	0.00 <sup>0</sup>	Table	Meet C3, C2, C3

# ARTS & CRAFTS PAVILION LEGO CHALLENGE

LEGO BUILDING - MAKE YOUR OWN DESIGN

## PRIZES TO BE WON!

### CATEGORIES

CLASS 27172 JUNIOR - UNDER 12 YEARS

CLASS 27173 JUNIOR - 13 TO UNDER 18 YEARS

CLASS 27174 SENIOR - 18 YEARS & OVER

CLASS 27175 SPECIAL NEEDS







**WENDY ERACHER**

JUDGED: *[Signature]*  
STEWARDS: *[Signature]*

SWEET  
CHILI  
SAUCE



CAIRNS SHOW 2015



**2nd**

Section 28  
Home Economics  
Jams And Preserves  
Open - Class 28078  
Sauce - Savoury  
Any Variety - 1 Bottle

**WENDY ERACHER**

JUDGED: *[Signature]*  
STEWARDS: *[Signature]*



**1st**

JUDGED:  
STEWARDS:

**CAIRNS  
SHOW**

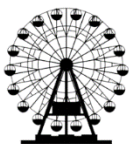

**16TH - 18TH  
JULY 2025**

**SECTION 28  
HOME ECONOMICS**

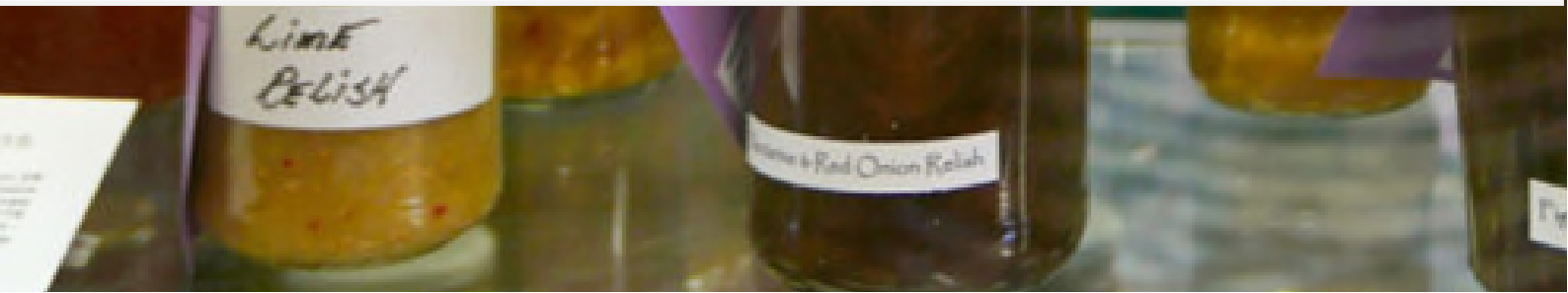

LIME  
RELISH

Tomato + Red Onion Relish

## SECTION 28 HOME ECONOMICS

### OFFICIALS

Chief Steward: Ms. Carol Coates

### KEY INFORMATION

**Entry Fee:** FREE

**Prize:** *As Stated*

#### Entries Close:

1. Cookery & Sweets: 4pm Tuesday 24th June.
2. Jams & Preserves: 4pm Tuesday 24th June.
3. Rich Fruit Cake: 4pm Tuesday 17th June.

#### Delivery of Exhibits:

All exhibits to be delivered at main door and collected from Centre Ring side of Arts and Crafts Hall under the De Jarlais Function Centre.

1. Cookery & Sweets: 8am-11am Tuesday 15th July.
2. Jams & Preserves: 9am-4pm Thursday 10th or Friday 11th July
3. Rich Fruit Cake: 8am-11am Tuesday 15th July.

#### Judging:

1. Cookery & Sweets: 1pm Tuesday 15th July.
2. Jams & Preserves: 9am Saturday 12th July.
3. Rich Fruit Cake: 1pm Tuesday 15th July.

**Collection of Exhibits:** 10am-2pm Saturday 19th July.

### SPONSORS

The Cairns Show Association wishes to record its sincere appreciation to the following Sponsors who have contributed to this area.

#### Showbag Warehouse

### HOW TO ENTER

1. Complete an Entry online or in person at the Cairns Show Office, or post via PO Box 811 Bungalow, QLD 4870.
2. Entries will not be accepted over the phone or after the closing date.
3. Entries must be delivered to the designated part of the Showgrounds by the due date time and date shown.

### AFTER THE SHOW

1. Prize Money can be collected between 9am and 4pm Monday to Friday 4th August to 29th August from the Show Office if your total prize money is less than \$50.
2. Proof of identity is required to collect Prize Money. If you are collecting prize money on behalf of someone else, a letter of authorisation from that person will be required.
3. All Prize Money less than \$50 not collected by 29th August, 4pm will be returned to the Cairns Show Association Funds.
4. Prize money of \$50 and over will be deposited to the entrant's nominated bank account after 29th August.
5. Results will be available from the [Cairns Show website](#) AFTER the conclusion of the Show.

## SPECIAL REGULATIONS

### PLEASE READ SPECIAL REGULATIONS FOR THE CLASS YOU ARE ENTERING THOROUGHLY.

1. Refer General Conditions of Entry & Competition in front of Schedule.
2. All exhibits must be the original and unaided work of the exhibitor. Factory made exhibits are not allowed in this Section.
3. No exhibit can be entered into more than one class.
4. Exhibitors should check exhibits for freshness - spoiled exhibits are automatically disqualified.
5. All cakes will be cut during the judging process.
6. All exhibits are to be on WHITE PAPER plates only, relevant to cake/slice size. Name and address to be written or attached on the back of the plate
7. Exhibitors Name and address and/or phone number must be on the back of the Class Card. Class Cards will be issued upon arrival.
8. Class Card must be affixed to the front of the paper plate. Please ensure your exhibit card is readable and visible when attached to your exhibit.
9. No person other than Judges and Stewards to be present while judging is in progress. Art & Crafts Pavilion will be locked during judging. The Judge reserves the right to alter the Class of an exhibit.
10. Out of town exhibitors may collect exhibits following the fireworks for 30 minutes on Friday night 18th July 2025. Prior arrangements to be made with the Chief Steward.
11. Exhibits may be collected from Ring Side of Arts and Crafts Hall 10am to 2pm, Saturday 19th July 2025. No responsibility will be taken for exhibits left in the Arts & Crafts Pavilion after this time. All food will disposed of.
12. No free passes are available to exhibitors.

**COOKERY****OPEN**

**All cake entries to be 1/2 of cake only for judging and display. Other ½ not to be entered.**

**Prize: 1st - \$8, 2nd - \$4, 3rd - Card**

Class 28001 Sponge Cake

**Any Variety - Jam filled.**

Class 28002 Any Bar Cake

Class 28003 Banana Cake

**Iced**

Class 28004 Boiled Fruit Cake

**Approx. 20cm Tin**

Class 28005 Dark Rich Fruit Cake

Class 28006 Any Other Fruit Cake

Class 28007 Office / Work Place Cake Challenge Cake

Class 28008 Packet Cake

**Iced and Decorated - Label Included**

Class 28009 Any Gluten Free Cake

**Recipe included.**

Class 28010 Any Vegan Cake

**Recipe Included.**

Class 28011 Infused Cake

**Non Cannibas, recipe included, eg. Earl Grey infused cake with vanilla butter cream.**

Class 28012 Any Other Cake Not Mentioned

**Must be Named.**

Class 28013 Boiled Plum Pudding

**Boiled in Cloth**

Class 28014 Steamed Plum Pudding

**Steamed in Basin**

**COOKERY – CONTINUED**

Class 28015 Plain Scones

**Plate of 6**

Class 28016 Pumpkin Scones

**Plate of 6**

Class 28017 Traditional Damper

**Plain, Sweet or Savoury, Flat or Domed**

Class 28018 Slices

**Plate of 6 (one mixture).**

Class 28019 Anzac Biscuits

**Plate of 6**

Class 28020 Biscuits

**Plate of 6 - Any Variety**

Class 28021 Decorated Biscuits

Class 28022 Shortbread

**Plate of 6**

Class 28023 Patty Cakes

**Decorated Plate of 6**

Class 28024 Cup Cakes

**Decorated Plate of 6**

Class 28025 Pikelets

**Plate of 6**

Class 28026 Muffins

**Plate of 6 - Any Variety**

**CHAMPION OF OPEN COOKERY SECTION - \$55**

**Prize: \$55 + Sash**

**COOKERY – CONTINUED****JUNIOR - 12 YEARS & UNDER**

**All cake entries to be 1/2 of cake only for judging and display. Other ½ not to be entered.**

**Prize: 1st - \$5, 2nd - \$3, 3rd - \$2**

Class 28027 Plain Scones

**Plate of 6**

Class 28028 Pikelets

**Plate of 6**

Class 28029 Anzac Biscuits

**Plate of 6**

Class 28030 Biscuits

**Plate of 6 - Any Variety**

Class 28031 Orange Bar Cake

**Iced**

Class 28032 Chocolate Ring Cake

**Iced**

Class 28033 Boiled Fruit Cake

Class 28034 Packet Mix Cake

**Iced & Decorated - Including Label**

Class 28035 Cup Cakes

**Decorated - Plate of 6**

Class 28036 Patty Cakes

**Decorated - Plate of 6**

Class 28037 Slices

**Plate of 6**

Class 28038 Arrowroot Biscuits

**Iced and Decorated - Plate of 6**

Class 28039 Muffins

**Plate of 6 - Any Variety**

Class 28040 Any Other Cake Not Mentioned

**Must be Named**

**CHAMPION OF JUNIOR COOKERY 12 YEARS & UNDER**

**Prize: Sash**

## COOKERY – CONTINUED

### **JUNIOR - 13 YEARS TO UNDER 18 YEARS**

**All cake entries to be 1/2 of cake only for judging and display. Other 1/2 not to be entered.**

**Prize: 1st - \$5, 2nd - \$3, 3rd - \$2**

Class 28041 Sponge Cake

**1 Layer**

Class 28042 Child's Birthday Cake

**Novelty - Decorated**

**Prize: 1st - \$10, 2nd - \$6, 3rd - \$4 (Class 28042 Only)**

Class 28043 Plain Scones

**Plate of 6**

Class 28044 Pikelets

**Plate of 6**

Class 28045 Anzac Biscuits

**Plate of 6**

Class 28046 Biscuits

**Plate of 6 - Any Varieties**

Class 28047 Decorated Biscuits

Class 28048 Orange Bar Cake

**Iced**

Class 28049 Chocolate Ring Cake

**Iced**

Class 28050 Boiled Fruit Cake

Class 28051 Packet Cake Mix

**Iced & Decorated - Including Label**

Class 28052 Cup Cakes

**Decorated - Plate of 6**

Class 28053 Patty Cakes

**Decorated - Plate of 6**

Class 28054 Slices

**Plate of 6**

Class 28055 Muffins

**Plate of 6 - Any Variety**

Class 28056 Any Other Cake Not Mentioned

**Must Be Named**

### **CHAMPION OF JUNIOR COOKERY 13 YEARS TO UNDER 18 YEARS - \$55**

**Prize: \$55 + Sash**

## SPECIAL NEEDS

**Prize:** 1st - \$5, 2nd \$4, \$2

### 12 YEARS & UNDER

**All Cake entries to be 1/4 of cake only for judging and display.**

Class 28057 Any Cake

Class 28058 Decorated Cake

**Any Cake**

Class 28059 Any Slice or Biscuit

**Plate of 6**

Class 28060 Decorated Biscuit

**Any Biscuit**

### CHAMPION SPECIAL NEEDS 12 YEARS AND UNDER

**Prize:** Sash 13 Years & Under 18 Years

### 13 YEARS & UNDER 18 YEARS

**All Cake entries to be 1/2 of cake only for judging and display.**

Class 28061 Any Cake

Class 28062 Decorated Cake

**Any Cake**

Class 28063 Any Slice or Biscuit

**Plate of 6**

Class 28064 Decorated Biscuit

**Any Biscuit**

### CHAMPION SPECIAL NEEDS 13 YEARS AND UNDER 18 YEARS

**Prize:** Sash

## SWEETS

### OPEN

**Prize:** 1st - \$8, 2nd - \$4, 3rd - Card

Class 28065 Rum or Fruit Balls

**Plate of 6**

Class 28066 Coconut Ice

**Plate of 6**

Class 28067 Chocolate Fudge

**Plate of 6**

Class 28068 Marshmallow

**Plain, Toasted or Fancy - Plate of 6**

Class 28069 Jellies

**Plate of 6**

Class 28070 Plate of Any Other Homemade Sweets



## SWEETS – CONTINUED

### **JUNIOR - UNDER 18 YEARS**

**Prize:** 1st - \$5, 2nd - \$3, 3rd - \$2

Class 28071 Fruit Balls

**Plate of 6**

Class 28072 Coconut Ice

**Plate of 6**

Class 28073 Chocolate Fudge

**Plate of 6**

Class 28074 Marshmallows

**Plain, Toasted or Fancy - Plate of 6**

Class 28075 Any Other Sweet Not Specified

**Plate of 6**

### **OVERALL CHAMPION OF JUNIOR SWEETS**

**Prize:** Sash

## JAMS & PRESERVES

**EXHIBITS:** All exhibits containing gelatine or artificial pectin will be disqualified.

**PRESERVES:** All preserve exhibits will only be accepted in jars ranging from approx. 120ml or 1/2 cup in size approximately.

**JAMS/SAUCES:** All jam/sauce exhibits will only be accepted in screw top jars/bottles not necessarily vacola type jars) ranging from 120ml or 1/2 cup in approximate size and labelled.

**No lid covers, including material covers.**

### **OPEN**

**Prize:** 1st - \$8, 2nd - \$4, 3rd - Card

Class 28076 Rosella Jam

**1 Jar**

Class 28077 Cumquat Jam

**1 Jar**

Class 28078 Jam - Any Variety from Dried Fruit

**1 Jar**

Class 28079 Jam - Any Other Variety

**1 Jar**

Class 28080 Orange Marmalade

**1 Jar**

Class 28081 Grapefruit Marmalade

**1 Jar**

Class 28082 Cumquat Marmalade

**1 Jar**

Class 28083 Marmalade - Any Other Variety

**1 Jar**

Class 28084 Jelly - Any Variety

**1 Jar**

Class 28085 Infused Jam, Jelly or Sauce

**Non Cannibas - 1 Jar**

## JAMS & PRESERVES – CONTINUED

Class 28086 Lemon Butter

**1 Jar**

Class 28087 Any Other Fruit Butter

**1 Jar**

Class 28088 Sauce - Savoury

**Any Variety - 1 Bottle**

Class 28089 Sauce - Dessert

**Any Variety - 1 Bottle**

Class 28090 Mayonnaise

**Any Variety - 1 Jar**

Class 28091 Relish

**Any Variety - 1 Jar**

Class 28092 Mango Chutney

**1 Jar**

Class 28093 Any Other Chutney

**1 Jar**

Class 28094 Pickles - Mustard

**Any Variety - 1 Jar**

Class 28095 Pickles - Clear

**Any Variety - 1 Jar**

Class 28096 Jam / Relish - Any Other Variety

Class 28097 Fruit Cordial

### **OPEN - COLLECTIONS**

**Each Collection to be 4 Varieties.**

**Prize:** 1st - \$10, 2nd - \$5, 3rd - Card

Class 28098 Collection of Jams or Marmalades

**4 Varieties**

Class 28099 Collection of Jellies

**4 Varieties**

Class 28100 Collection of Chutney & Relishes

**4 Varieties**

Class 28101 Collection of Preserved Fruit & Vegetables

**4 Varieties**

### **CHAMPION OPEN JAMS AND PRESERVES OF SHOW - \$20**

**Prize:** \$20 + Sash

**JAMS & PRESERVES – CONTINUED****JUNIOR - UNDER 18 YEARS****100ml or 1/2 cup in size.****Prize: 1st - \$5, 2nd - \$3, 3rd - \$2**

Class 28102 Jam

**Any Variety - 1 Jar**

Class 28103 Jelly

**Any Variety - 1 Jar**

Class 28104 Marmalade

**Any Variety - 1 Jar**

Class 28105 Butter

**Any Variety - 1 Jar. Example: Lemon, Passionfruit, etc.**

Class 28106 Chutney

**Any Variety - 1 Jar**

Class 28107 Relish

**Any Variety - 1 Jar**

Class 28108 Pickles

**Any Variety - 1 Jar****CHAMPION JUNIOR JAMS AND PRESERVES OF SHOW - \$10****Prize: \$10 + Sash**



**CAIRNS  
SHOW**



**16TH - 18TH  
JULY 2025**

**SECTION 29  
ICED CAKES**



## SECTION 29 ICED CAKES

### OFFICIALS

Chief Steward: Ms. Carol Coates

### KEY INFORMATION

**Entry Fee:** *As Stated.*

**Prize:** *As Stated.*

**Entries Close:** 4pm Friday 20th June. Entries on the day of Delivery may be accepted.

**Delivery of Exhibits:** 7am-11am Tuesday 15th July WIN News Arts & Crafts Pavilion (underneath De Jarlais Function Centre).

**Judging:** 1pm Tuesday 15th July.

**Collection of Exhibits:** 10am-2pm Saturday 19th July - Main Arena (Centre Ring) side of Arts & Crafts Hall.

### SPONSORS

The Cairns Show Association wishes to record its sincere appreciation to the following Sponsors who have contributed to this area.

**Channel 9 WIN News, Showbag Warehouse, Showbag Counsel, and Queensland Cake Decorators Association - Cairns Branch**

### HOW TO ENTER

1. Complete an Entry online or in person at the Cairns Show Office, or post via PO Box 811 Bungalow, QLD 4870.
2. Entries will not be accepted over the phone or after the closing date.
3. Pay for Entry Fees online, by direct deposit, or in person at the Cairns Show Office (cash accepted).
4. Entries must be delivered to the designated part of the Showgrounds by the due date time and date shown.

### AFTER THE SHOW

1. Exhibits NOT collected by Friday 29th August 2024 will become Property of the Cairns Show Association.
2. Prize Money can be collected between 9am and 4pm Monday to Friday, 4th August to 29th August from the Show Office if your total prize money is less than \$50.
3. Proof of identity is required to collect Prize Money. If you are collecting prize money on behalf of someone else, a letter of authorisation from that person will be required.
4. All Prize Money less than \$50 not collected by 29th August, 4pm will be returned to the Cairns Show Association Funds.
5. Prize money of \$50 and over will be deposited to the entrant's nominated bank account after 29th August.
6. Results will be available from the [Cairns Show website](#) AFTER the conclusion of the Show.



## SPECIAL REGULATIONS

### PLEASE READ SPECIAL REGULATIONS FOR THE CLASS YOU ARE ENTERING THOROUGHLY

1. Refer General Conditions of Entry & Competition in front of Schedule.
2. Exhibits may be collected from 10am-2pm Saturday 19th July. No responsibility will be taken for exhibits left in the Arts & Craft Pavilion after this time. Out of Town exhibitors may collect exhibits following the Fireworks for 30 minutes on Friday night 18th July 2024. Prior arrangements must be made with the Chief Steward.
3. Exhibits for sale must be clearly marked and cannot be removed until Saturday 19th July.
4. Commission of 20% will apply to all cakes sold and must be included in the sale price.
5. No person other than Judges and Stewards to be present throughout duration of Judging. The Judge reserves the right to alter the Class of an exhibit.
6. In the event of an exhibit in any one class not being worthy of a prize, no prize money, gift, etc, will be awarded
7. No exhibit can be entered into more than one class.
8. No free passes available to exhibitors.
9. Entries that are not completed according to this schedule may be ineligible for a prize.
10. All entries to be the bona fide handiwork of the exhibitor
11. For All Classes the base, presentation board or drape must fit within the perimeter of a 45cm square. The base boards must be raised on cleats or runners. Pillars or other means of elevating cakes are permitted.
12. Except where specifically otherwise mentioned, no non-sugar ornaments are allowed. No artificial paper, fabric flowers or leaves to be used and dried baby's breath is not permitted. However, minimal use of dried vegetable matter (e.g. polenta & semolina) may be used.
13. Reasonable use of wire, tape, stamens, ribbons, cotton, tulle, gelatine, piping gel & posy pics are permitted. However, wire of any kind MUST NOT penetrate the surface of the exhibit, and no pins are allowed to hold ribbons, etc.
14. Only minimal amounts of metallic paint and lustres will be allowed except for Open Contemporary Design.
15. Information sheets for the Judges should be completed.
16. To advise use of supports.
17. To clarify use of any item which may appear not to comply with schedule.
18. For any explanation necessary to clarify exhibit.
19. To clarify if your cake is a "Dummy".
20. Name, Address & Phone Number on the back of Class Card.
21. SECTIONS MARKED "JUNIOR" - Only children under 18 years are eligible to enter Junior Sections
22. SECTIONS MARKED "NOVICE" - Novice Sections are only for exhibitors who have never won a first prize in this class or any prize in the Open class and have not entered on more than four previous occasions.
23. SECTIONS MARKED "INTERMEDIATE"- Intermediate Sections are only for exhibitors who have never won a first prize in this class or any prize in the Open Class and have not entered on more than four previous occasions.
24. SECTIONS MARKED "OPEN" - Open Sections can be entered by anyone irrespective of previous wins.
25. Dummy Cakes may be used except in Class 29010 Novelty, where cake must be used to form shape.
26. Translation card (if necessary) attached to item on the right-hand corner at the front.
27. The Cairns Show Association is unable to provide refrigerated cabinets and accepts no responsibility for the condition of buttercream cakes stored for more than four days.

## SPECIAL REGULATIONS – CONTINUED

### POINTS OF INTEREST

1. **Bona fide Handiwork:** Must be handmade solely by the exhibitor.
2. **Sugar Paste:** Decorations made from sugar.
3. **Lace:** A piece of lace that is piped with royal icing.
4. **Extension work:** Piped with royal icing giving a delicate border finish to lower side sections of cake.
5. **Piping skills:** Royal icing that is piped directly on to the surface of the iced cake.
6. **Cleats or Runners:** Cleats must be adhered under boards sufficient to enable ease of handling.
7. **Pillars:** Supports tiered cakes - usually made in plastic, they come in different shapes and sizes.
8. **Wire:** Covered wire.
9. **Tape:** Florist tape to bind wire.
10. **Posy Pics:** Small plastic cone shaped holder.



## JUNIOR SECTION

**Entry Fee:** \$1.10

**Prize:** 1st - \$20 + Trophy + Gift Voucher, 2nd - \$10, 3rd - \$8

### **11 YEARS & UNDER**

**Open to Children up to and including 11 Years.**

Class 29001 Iced Cake

**Any theme - to be judged on the originality of design and execution**

Class 29002 Sugar Craft - No Cake Included

**Floral arrangement and/or novelty. To be an imaginative creation, judged for ingenuity of design and execution, and arranged on a base board, no longer than 45cm x 45cm.**

### **12 YEARS TO UNDER 18 YEARS**

**Open to Children 12 Years to Under 18 Years.**

Class 29003 Iced Cake

**Any theme - to be judged on originality of design and execution.**

Class 29004 Sugar Craft - No Cake Included

**Floral arrangement and/or novelty. To be an imaginative creation, judged for ingenuity of design and execution, and arranged on a base board, no longer than 45cm x 45cm.**

## NOVICE SECTION

**Shop Owners, Tutors and Online Businesses can ONLY enter in the Open Section.**

**Entry Fee:** \$1.10

**Prize:** 1st - \$20 + Gift Voucher, 2nd - \$10 + Gift Voucher, 3rd - \$8

Class 29005 Special Occasion Cake

**One- or two-tier Cake can be Wedding, Engagement, Birthday, Christening, Anniversary, Christmas, Easter Theme, etc. For exhibitors who have never won a first prize in this class or any prize in the Open Class and have not entered on more than four previous occasions.**



## INTERMEDIATE SECTION

**Shop Owners, Tutors and Online Businesses can ONLY enter in the Open Section.**

**Entry Fee:** \$4.40

**Prize:** 1st - \$20 + Gift Voucher, 2nd - \$15 + Gift Voucher, 3rd - \$10

Class 29006 Special Occasion Cake

**One- or two-tier cake can be Wedding, Engagement, Birthday, Christening, Anniversary, Christmas, Easter Theme, etc. Open to those who have not previously won a first prize in this Class or any prize in the Open Class and have not entered on more than four occasions.**

## OPEN SECTION

**Entry Fee:** \$4.40

**Prize:** *As Stated.*

Class 29007 Special Occasion Cake

**One Cake only (excluding Wedding Cake). Example: Engagement, Birthday, Christening, Anniversary, Christmas, Easter Theme, etc. Open to all exhibitors.**

Class 29008 Wedding Cake

**Two or three cakes to be tiered or otherwise presented on a common base board.**

Class 29009 Contemporary Design

**One or two cakes to be tiered or otherwise presented on a common base board, decorated using up to 5 cutters/tools. To be judged for ingenuity of design and execution of cutters. A minimum of three different types of cutters/tools must be used. Lustre, glitter, cachous, wires, rope, moulds, cutters, stencils, supports, pillars, perspex, colour, may be used but no artificial (e.g. silk flowers) or plastic (e.g. Bride and Groom) decorating items.**

Class 29010 Novelty Cake

**The exhibit MUST be sculptured from a cake. Cake content must be at least 50%. The remaining 50% must be edible content (no dummies), the cake and other content to be noted on the Judged information sheet. Arrange on a base no bigger than 45cm x 45cm.**

Class 29011 Sugar Craft -No Cake Included

**Floral arrangement and/or novelty. To be an imaginative creation, judged for ingenuity of design and execution, and arranged on a base board, no bigger than 45cm x 45cm. All exhibitors are eligible to enter this class.**

**BUTTERCREAM**

**Entry Fee:** \$4.40

**Prize:** 1<sup>st</sup> - \$25 Gift Voucher, 2nd - \$20 Gift Voucher.

Class 29012 Special Occasion Cake

**One- or two-tier Cake can be Wedding, Engagement, Birthday, Christening, Anniversary, Christmas, Easter Theme etc. Open to all exhibitors.**



# CAIRNS SHOW 2018

AWARDED TO: *ROB MURCHIE*  
Section 31 - Woodwork



**CAIRNS  
SHOW**



**16TH - 18TH  
JULY 2025**

**SECTION 31  
WOODWORK**

## SECTION 31 WOODWORK

### OFFICIALS

Chief Steward: Ms. Carol Coates

### KEY INFORMATION

**Entry Fee:** \$5 - *unless Otherwise Stated.*

**Prize:** 1st - \$20, 2nd - \$10, 3rd - \$5 - *unless Otherwise Stated.*

**Entries Close:** 4pm Friday 5th July.

**Delivery of Exhibits:** 9am-4pm Tuesday 8th July and Friday 11th July - WIN News Arts & Crafts Pavilion (underneath De Jarlais Function Centre).

**Judging:** 9am Saturday 12th July.

**Collection of Exhibits:** 10am-2pm Saturday 19th July - Main Arena (Centre Ring) side of Arts & Crafts Hall.

### SPONSORS

The Cairns Show Association wishes to record its sincere appreciation to the following Sponsors who have contributed to this area.

#### Showbag Warehouse

### HOW TO ENTER

1. Complete an Entry online or in person at the Cairns Show Office, or post via PO Box 811 Bungalow, QLD 4870.
2. Entries will not be accepted over the phone. Entries may be accepted on the day of Delivery (subject to approval of the Chief Steward).
3. Pay for Entry Fees online, by direct deposit, or in person at the Cairns Show Office (cash accepted).
4. Entries must be delivered to the designated part of the Showgrounds by the due date time and date shown.

### AFTER THE SHOW

1. Exhibits NOT collected by Friday 29th August 2025 will become Property of the Cairns Show Association.
2. Prize Money can be collected between 9am and 4pm Monday to Friday 4th August to 29th August from the Show Office if your total prize money is less than \$50.
3. Proof of identity is required to collect Prize Money. If you are collecting prize money on behalf of someone else, a letter of authorisation from that person will be required.
4. All Prize Money less than \$50 not collected by 29th August, 4pm will be returned to the Cairns Show Association Funds.
5. Prize money of \$50 and over will be deposited to the entrant's nominated bank account after 29th August.
6. Results will be available from the [Cairns Show website](#) AFTER the conclusion of the Show.

## SPECIAL REGULATIONS

### PLEASE READ SPECIAL REGULATIONS FOR THE CLASS YOU ARE ENTERING THOROUGHLY

1. All exhibitors must enter woodwork into the appropriate class, e.g. Novice, Intermediate or Open.
2. Novice Class is open to exhibitors who have never won a prize in the Woodwork Section in any previous competition and have not entered on more than two previous occasions and have never entered an exhibit in an Intermediate or Open Class.
3. Open Class is open to all exhibitors.
4. All exhibits for sale must be clearly marked with price. Exhibits not for sale must be marked "NFS". Commission of 20% will apply to all works sold and must be included in the sale price. Please liaise with Chief Steward.
5. Exhibits to be collected from 10 am to 2pm Saturday 20th July 2024. No responsibility will be taken for exhibits left in the Woodwork Section after this time.
6. Sold exhibits must not be removed until Saturday 19th July 2025.
7. Entrants must use at least 90% timber in their creations and all creations must be made in the last 12 months prior to the Cairns Show 2025.
8. In the event of an exhibit in any one class not being worthy of a prize, no prize money will be awarded.
9. No persons other than the Chief Steward and Judge are to touch exhibits prior to Judging on Saturday 12th July 2025. The Judge reserves the right to alter the Class of an exhibit.
10. All exhibits are to be the original and unaided work of the exhibitor. Any exhibitor found to be aided by others in completing his/her exhibit will be disqualified.
11. NO EXHIBITS ARE TO BE PAINTED. PAINTED EXHIBITS WILL NOT BE JUDGED.
12. \*If you wish to just display your items, please contact the office to discuss further.



## WOODWORK CRAFTED

### NOVICE

**Novice Class is open to exhibitors who have never won a prize in the Woodwork Section in a previous competition and have not entered on more than two previous occasions and have never entered an exhibit in the Intermediate or Open Classes.**

Class 31001 Novice Small

Class 31002 Novice Medium

Class 31003 Novice Large

### OPEN

Open Class is open to all exhibitors.

Class 31004 Open Small

Class 31005 Open Medium

Class 31006 Open Large

## MARQUETRY & WOOD TURNING

**Examples of Wood Turning: Spindle, plate or bowl turning, carving/hollow vessel turning, offset marquetry and other turned items, pens, jewellery boxes, ring boxes, etc.**

**Examples of Marquetry: Marquetry can be any size exhibit and must include timber inlay.**

### NOVICE

Class 31007 Novice Marquetry

Class 31008 Novice Spindle

Class 31009 Novice Face Plate

Class 31010 Novice Combination

### OPEN

Class 31011 Open Marquetry

Class 31012 Open Spindle

Class 31013 Open Face Plate

Class 31014 Open Combination

**Can include metal.**

Class 31015 Intermediate Face Plate

Class 31016 Woodburning

## WOOD SCULPTURE

Class 31017 Wood Sculpture - Open

## WOOD CARVING

Class 31018 Wood Carving - Open

## RESTORATION

Class 31019 Any Item

**Must include a before photo.**



## REPURPOSE

Class 31020 Repurpose Item

**Can use up to 20% new material. Please provide a photo were possible of items/articles that it is made from along with a description and use.**

**MOST ORIGINAL EXHIBIT - \$20**

**Prize: \$20 + Trophy + Sash**

**GRAND CHAMPION - \$50**

**Prize: \$50+ Trophy + Sash**

## SCHOOL ENTRIES

**Entry Fee: \$2.50**

**School entry is open to school groups.**

Class 31021 Small Woodwork Crafted

Class 31022 Medium Woodwork Crafted

Class 31023 Marquetry

Class 31024 Spindle

Class 31025 Face Plate

Class 31026 Combination

**Can include Metal.**

**SCHOOL CHAMPION - \$50**

**Prize: \$50 + Trophy + Sash**





# SPONSORS

## THANK YOU!

The Cairns Show Association wishes to record its sincere appreciation to the following Cairns Show Sponsors who have contributed to this event.



SPONSORS



# CAIRNS SHOW 16TH -18TH SHOW JULY 2025



## CAIRNS SHOW ASSOCIATION

109-127 Mulgrave Rd, Paramatta Park, QLD 4870

PO Box 811, Bungalow, QD 4870

PH: (07) 4042 6699 | FAX: (07) 4031 3671

Email: [competitions@cairns-show.com](mailto:competitions@cairns-show.com)

Website: [www.cairnsshow.com.au](http://www.cairnsshow.com.au)

## ARTS & CRAFT COMPETITION SCHEDULE