

COMPETITION SCHEDULE



**CAIRNS
SHOW**



**15TH - 17TH
JULY 2026**

**SECTIONS
23, 24, 25, 26, 27,
28, 29 & 31
ARTS & CRAFT**



CAIRNS SHOW COMMITTEE 2026

Honourary Historian & Patron: Mr. Ley James
President: Mr. Ian Allen
Treasurer: Ms. Narelle Phipps
Senior Vice President: Mr. Glen Hunter
Assistant Treasurers: Mr. Christopher Van Dorssen
Executive Vice President: Mr. Bevan Clayton
Mr. Desmond Tong
Mr. Francis (Ley) James
Mr. Nathan Lee Long
Management Committee: Mrs. Carolyn Allen
Mr. Leslie Plath
Mr. Daniel Sale
Mr. Michael Tonion
Mr. Louis Underwood
General Committee: Ms. Judy Alyce
Mrs. Janice Anderson
Mr. Raven Cook
Ms. Grace Davis
Mr. Michael Fischer
Mr. David Green
Ms. Amanda Hunter
Ms. Glenda McAuliffe
Mr. Warren March
Mr. Malcom O'Hara
Mr. Robert O'Malley
Mr. Michael Pattini
Ms. Snjezana Tuhega
Mrs. Christine Stoddart
Mr. Robert Stoddart
Mr. Mike Walton

CAIRNS SHOW STAFF 2026

Manager/Secretary: Mr. Ian Moller-Nielsen
Events Coordinator: Miss. Heather Rowlands
Venues/Sites Coordinator: Ms. Emily Barker
Finance Officer: Mrs. Naomi Stewart
Receptionist: Ms. Samantha Martin
Mr. Anthony Miano
Mr. Jeremy Pyke
Groundsman: Mr. Adam Pritchard

WELCOME FROM THE PRESIDENT

Welcome to Australia's largest regional agricultural show, where we proudly celebrate the very best of Far North Queensland's agriculture, industry, culture, and community. Each year, the Cairns Show brings the country to the city, uniting families, honouring traditions, and connecting generations.

Our Show offers an exciting and diverse program featuring competitions, exhibits, entertainment, and hands-on experiences. From livestock and equestrian events to arts, photography, cooking, and horticulture, we are proud to showcase the exceptional talent and passion that make our region unique. And with Queensland's largest Sideshow Alley right here at the Cairns Show, there is truly something for everyone to enjoy.

This year holds special significance as we celebrate the 121st Cairns Show alongside Cairns' 150th Anniversary - a meaningful milestone that allows us to reflect on our shared history, acknowledge the progress of our region, and celebrate the community spirit that continues to define us.

I would like to extend my sincere thanks to the Federal and State Governments and the Cairns Regional Council for their valued support of the show. I also wish to acknowledge our dedicated staff, committee members, volunteers, sponsors, and exhibitors - and, of course, our visitors. Your ongoing support and enthusiasm are what make this iconic event possible year after year.

With so much to explore, one day at the Cairns Show is never enough - so come along, immerse yourself in the festivities, and enjoy everything that makes our Show truly special.

Enjoy the 2026 Cairns Show!



Mr. Ian Allen

President, Cairns Show Association

Cairns Agricultural, Pastoral, and Mining Association



ESSENTIAL SHOW INFORMATION

Cairns Show

Wednesday 15th, Thursday 16th, and Friday 17th July 2026

Gate Opening Times:

9:00am - 9:00pm daily

Please note: Some attraction closing times may vary.

Cairns Show Map:

The Cairns Show Map is available at all gate entrances, in the Cairns Show Guide, and online via the Cairns Show website, Facebook, and Instagram pages.

Gate Entrances:

1. Corner of Severin Street and Mulgrave Road (Main Gates)
2. Quigley Street
3. Mulgrave Road (in front of the Fred Moule Exhibition Centre)
4. Scott Street

Taxi Ranks:

1. Mulgrave Road (in front of the Honey Providore Horticulture Pavilion)
2. Scott Street (near St Augustine's College)
3. Corner of Mulgrave Road and Severin Street

Bus Stops:

Sunbus Pickup and Drop Offs Points:

- To the City – Mulgrave Road (opposite the Showground Main Entrance)
- From the City – Mulgrave Road (in front of the Cairns Youth Centre)
- Disability Set-Down – Corner of Mulgrave Road and Severin Street

Accessible Parking:

Parking Bay Locations:

- 5 bays on Severin Street (near Mulgrave Road)
- 5 bays on Severin Street (outside St Augustine's College Swimming Pool)

Toilets:

Please refer to the Cairns Show Map for toilet locations.

ATMS:

1. Inside the Main Gate entrance (in front of the Cairns Show Office)
2. Outside the Fred Moule Exhibition Centre
3. Inside the Scott Street entrance (next to Sideshow Alley rides).

First Aid:

1. Medical Outpost (near the Main Gate entrance)
2. Clive Gordon Main Arena (Centre Ring)
3. Opposite the Animal Nursery

Smoking:

The Cairns Show is a smoke-free environment. Smoking is only permitted in clearly signed, designated areas. Please refer to the Cairns Show Map for locations.

Cloakroom:

Located next to the Show Office. Volunteers from the FNQ Hospital Foundation will look after your items while you enjoy the Show. Free sunscreen is available.

Wheelchair/Trolley Hire:

Wheelchair and trolley hire is not available. Please come prepared and refer to the Cairns Show Map for rest areas and First Aid locations.

Dogs & Animals:

Dogs and animals are not permitted, except for service/guide dogs, approved medical support animals (ID required), and authorised Dog Show competitors.

GATE ADMISSION CHARGES

TICKETING INFORMATION

1. Purchasing Tickets Online is strongly encouraged. To purchase tickets online, please visit the Cairns Show website at www.cairnsshow.com.au.
2. Presold (discounted) tickets will be available at Pre-Sold Ticket Booth and Online. Please refer to the information below for pre-sale ticket purchasing details.
3. Tickets will also be available for purchase at the gates during the Show. Cashless payment is preferred; however, limited ATMs will be available across the grounds. Please refer to the Cairns Show Map for ATM locations.
4. Please note: A transaction fee per order applies to all ticket purchases, both online and in person, and is payable to the ticketing merchant.
5. By purchasing a ticket, you agree to the Terms and Conditions outlined on the Cairns Show website.

PRESOLD TICKETS

Discounted Presold Tickets can be purchased online at www.cairnsshow.com.au or in person at Earville Shopping Town from **Monday 6 July to Monday 13 July**, between 9:00am and 5:00pm.

On **Tuesday 14 July**, tickets will be available at the Main Gates of the Cairns Showgrounds from 9:00am to 5:00pm. After 5:00pm, tickets will only be available for purchase online.

Presold Ticket Types:

Valid for One Day – Any Day of the Cairns Show

- **Adults (18 years and over) - \$30**
- **Concession/Pension - \$24***
 - For individuals 14 years and over with a valid Student ID or Pensioner Card
 - *A discounted Concession/Pension voucher may be published in the local newspaper, offering One Day – Any Day entry at \$21. Please refer to the Cairns Show website for details.*
- **Child (5 years to under 14 years) - \$16**
- **Child (Under 5 years) - FREE**
- **Family Pass (2 Adults & 2 Children) - \$75**
 - Children must be aged 5 years to under 14 years
 - Family members will receive individual tickets, allowing entry at different times on the same day

TICKETS AT THE GATE

From **12:00am Wednesday 15 July**, ticket prices will revert to standard gate pricing as listed below.

Ticket at the Gate Types:

Valid for One Day – Any Day of the Cairns Show

- **Adults (18 years and over) - \$30**
- **Concession/Pension - \$24**
 - For individuals 14 years and over with a valid Student ID or Pensioner Card
- **Child (5 years to under 14 years) - \$16**
- **Child (Under 5 years) - FREE**
- **Family Pass (2 Adults & 2 Children) - \$78**
 - Children must be aged 5 years to under 14 years
 - Family members will receive individual tickets, allowing entry at different times on the same day

BONUS DOLLARS

1. Bonus Dollars are not available for purchase online.
2. One sheet of Bonus Dollars costs \$25 and provides \$30 value.
3. Bonus Dollars are valid for use in Sideshow Alley only and can be redeemed on rides, food, and games.
 - Not redeemable for Showbags
 - Not transferable
 - Cannot be replaced if lost, stolen, or misplaced
 - Unused tickets are non-refundable

CAIRNS SHOW ASSOCIATION MEMBERSHIP

CAIRNS SHOW MEMBERSHIP INFORMATION

Become a Member of the Cairns Agricultural, Pastoral and Mining Association (CAPMA) and enjoy a range of benefits across the Cairns Show, Cairns Show Wine Awards, Cairns Show Auto Spectacular, and other events throughout the year.

1. To apply for membership and view the full list of member benefits, please visit our website.
2. All membership types include three-day entry to the Cairns Show.
3. Membership applications and renewals open January 2026 and close **Friday 10 July 2026**.
4. Membership is valid for the membership year ending **31 December 2026**. The Cairns Show Association reserves the right to refuse any application. Memberships are limited and subject to availability.
5. By purchasing a Cairns Show ticket, membership, and/or Bonus Dollars, the holder agrees to the CAPMA Copyright, Privacy Policy, and Disclaimer.

MEMBERSHIP TYPES:

Annual Membership - \$120

Or \$1200 for a Permanent 10-Year Membership

CAPMA Members aged 18 years and over receive the following benefits:

1. One (1) Member's Shield providing unrestricted three-day entry to the Cairns Show (single person entry).
2. One (1) Member's Guest Shield providing unrestricted three-day entry to the Cairns Show (non-transferable, single person entry).
3. Access to the De Jarlais Members Pavilion during the Cairns Show. *(Buffet and bar are not included and are payable directly to vendors on the day.)*
4. Access to exclusive Member deals during the Cairns Show

ShowTime Membership - \$65

Available as part of the ShowTime promotional offer only.

ShowTime Members receive the following benefits:

1. One (1) Member's Shield providing unrestricted three-day entry to the Cairns Show (single person entry).
2. Access to the De Jarlais Members Pavilion during the Cairns Show. *(Buffet and bar are not included and are payable directly to vendors on the day.)*
3. Access to exclusive Member deals during the Cairns Show.

Concession Membership - \$24

CAPMA Members aged 14 years to under 18 receive:

1. One (1) Member's Shield providing unrestricted three-day entry to the Cairns Show (single person entry).
2. Access to the De Jarlais Members Pavilion during the Cairns Show.
 - Buffet and bar are not included and are payable directly to vendors on the day.)
 - Members under 18 years must be always accompanied by an adult.

Concession Members aged 18 years and over receive the above, plus:

- Must hold and present valid Concessional Student Identification.
- Access to exclusive Member deals during the Cairns Show.

Child Membership - \$17

CAPMA Members aged 5 years to under 14 receive:

1. One (1) Member's Shield providing unrestricted three-day entry to the Cairns Show (single person entry).
2. Access to the De Jarlais Members Pavilion during the Cairns Show.
 - Buffet and bar are not included and are payable directly to vendors on the day.)
 - Members under 18 years must be always accompanied by an adult.

GENERAL CONDITIONS - COMPETITIONS

ENTRY & COMPETITIONS

This Show operates in accordance with the regulations of the Queensland Chamber of Agricultural Societies, the Constitution and Rules of the Cairns Agricultural, Pastoral and Mining Association (CAPMA), and the regulations outlined within each section of this Show Schedule. In the event of any inconsistency, the rules and regulations contained within this Society's Schedule will take precedence.

For detailed information on the Queensland Chamber of Agricultural Societies regulations, please visit www.queenslandshows.com.au.

By participating in any class within this Schedule, all exhibitors and competitors agree to indemnify the Cairns Agricultural, Pastoral and Mining Association against any liability for accidents, damage, loss, or illness involving any exhibit, exhibitor, or competitor. All competitions are conducted under the full authority of CAPMA, and all decisions made by the Association are final.

THE CAIRNS AGRICULTURAL PASTORAL AND MINING ASSOCIATION

1. Competition entries and membership applications will not be accepted over the phone.
2. Each Section will have an appointed Chief Steward responsible for representing that Section in all matters. Failure to follow lawful directions from Stewards, Committee Members, or Staff, or any form of verbal or physical abuse, may result in disciplinary action, including exclusion from competitions and/or removal from the Cairns Showgrounds.
3. Judges will be appointed, and all judging decisions are final. No correspondence, verbal or written, will be entered.
4. **The Association reserves the right to make decisions, additions, or amendments to this Schedule, including Conditions of Entry and Special Regulations, without notice.**
5. By entering any competition, exhibitors acknowledge and agree to comply with all Conditions of Entry.
6. Judges must not have access to any information beyond that provided by CAPMA. Vice Presidents are not permitted to compete in sections under their direct control.

ANIMAL AND BIRD EXHIBITORS

1. All animal and bird exhibitors must complete an Exhibit Health Declaration upon delivery of their entry and comply with all health requirements outlined in the declaration. Forms are available from the Show Office or at www.cairnsshow.com.au.
2. Animal owners are responsible for all veterinary costs incurred. The Cairns Show will not cover veterinary expenses.
3. Entry to the grounds is subject to the following conditions:
 - a. Glass items are prohibited on the grounds.
 - b. All electrical leads must be tested and tagged in accordance with relevant industrial regulations.
 - c. Dogs must be always kept on a leash.

PRIZE MONEY & GST

Prize money listed in the Schedule is exclusive of GST. GST will be added for exhibitors registered for GST purposes. The Association will issue a Recipient Created Tax Invoice to eligible exhibitors.

PRIVACY STATEMENT

The Cairns Show Association collects and uses information provided in membership and competition entry applications to deliver member services and to organise and conduct competitions. By applying for membership or entering competitions, you consent to providing personal details such as name, address, and exhibit information. Competition results and details may be shared with media and included in publications. Your personal information will not be disclosed for any other purpose without your consent, unless required by law.



**CAIRNS
SHOW**



**15TH - 17TH
JULY 2026**

SECTION 23

BUMMA BIPPERA MEDIA

98.7 FM

INDIGENOUS ARTS



SECTION 23 BBM 98.7 FM INDIGENOUS ARTS

OFFICIALS

Chief Steward:

KEY INFORMATION

Entry Fee: FREE

Prize: As Stated

Entries Close: 4pm **Friday 17th June.**

Delivery of Exhibits: 12pm-5pm **Wednesday 8th July** - Cairns Show Office

Judging: 10am **Wednesday 15th July 2026**

SPONSORS

The Cairns Show Association wishes to record its sincere appreciation to the following Sponsors who have contributed to this area.

Cairns Agricultural, Pastoral and Mining Association, Bumma Bippa 98.7, Showbag Warehouse and The National Indigenous Australians Agency (NIAA)

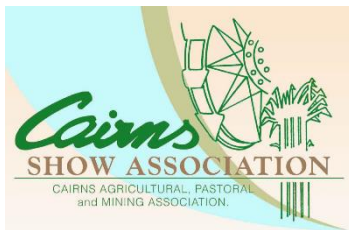

HOW TO ENTER

1. Complete an Entry online or in person at the Cairns Show Office, or post via PO Box 811 Bungalow, QLD 4870.
2. Entries will not be accepted over the phone or after the closing date.
3. Pay for Entry Fees online, by direct deposit, or in person at the Cairns Show Office (cash accepted).
4. Entries must be delivered to the designated part of the Showgrounds by the due date time and date shown.

AFTER THE SHOW

- Exhibits NOT collected by **Friday 21st August 2026** will become Property of the Cairns Show Association.
- Prize Money can be collected between 9am and 4pm Monday to **Friday 1st August to 29th August** from the Show Office if your total prize money is less than \$50.
- Proof of identity is required to collect Prize Money. If you are collecting prize money on behalf of someone else, a letter of authorisation from that person will be required.
- All Prize Money is less than \$50 not collected by **29th August, 4pm 2026** will be returned to the Cairns Show Association Funds.
- Prize money of \$50 and over will be deposited to the entrant's nominated bank account after **29th August.**
- Results will be available from the [Cairns Show website](#) AFTER the conclusion of the Show.
- Indigenous Arts

SPECIAL REGULATIONS

- Refer to General Conditions of Entry and Competition in front of this Schedule.
- This competition is for Indigenous arts and crafts only. Exhibits must have an Indigenous element either traditional or modern.
- Indigenous arts are open to all ethnic backgrounds.
- All exhibits must be the original work of the exhibitor.
- Each exhibit may be entered in only one class.
- All exhibits in Junior Classes must include date of birth on entry form.
- In the event of an exhibition in any one class not being worthy of a prize, no prize will be awarded.
- Exhibits will be displayed in a designated Gallery in the Fred Moule Pavilion.
- Exhibits are not limited to size restrictions.
- Canvas may be used.
- No free passes available to exhibitors

CELEBRATING STORYTELLING THROUGH ART

For thousands of years, Aboriginal and Torres Strait Islander peoples have shared stories through art - passing down knowledge, culture, traditions, and connection to Country from generation to generation.

Art is more than paint on a canvas. It is storytelling. It is history. It is identity. Every piece carries meaning, whether it reflects family, community, landscapes, animals, dreaming stories, or personal journeys.

The Cairns Show Indigenous Arts Competition proudly celebrates both traditional and contemporary Indigenous art forms, providing a space for artists of all ages to share their creativity and culture with the wider community.

This competition is about more than winning prizes - it is about encouraging expression, celebrating culture, inspiring future generations, and recognising the incredible artistic talent that exists throughout Far North Queensland and beyond.

We are honoured to showcase these works and thank every artist who shares a piece of their story with us.

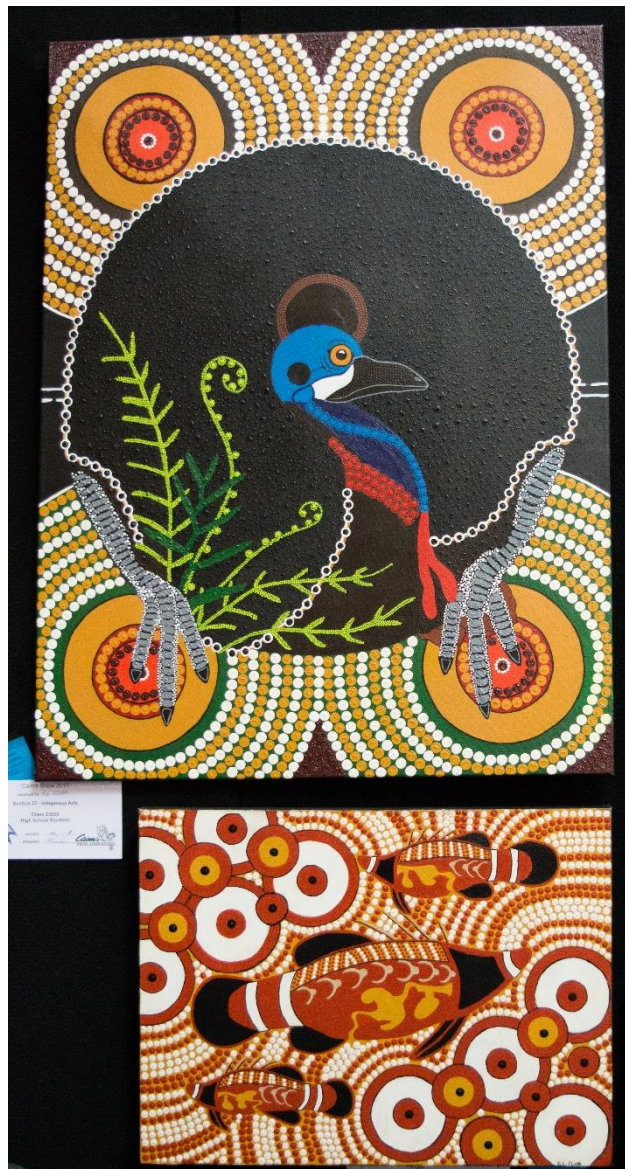

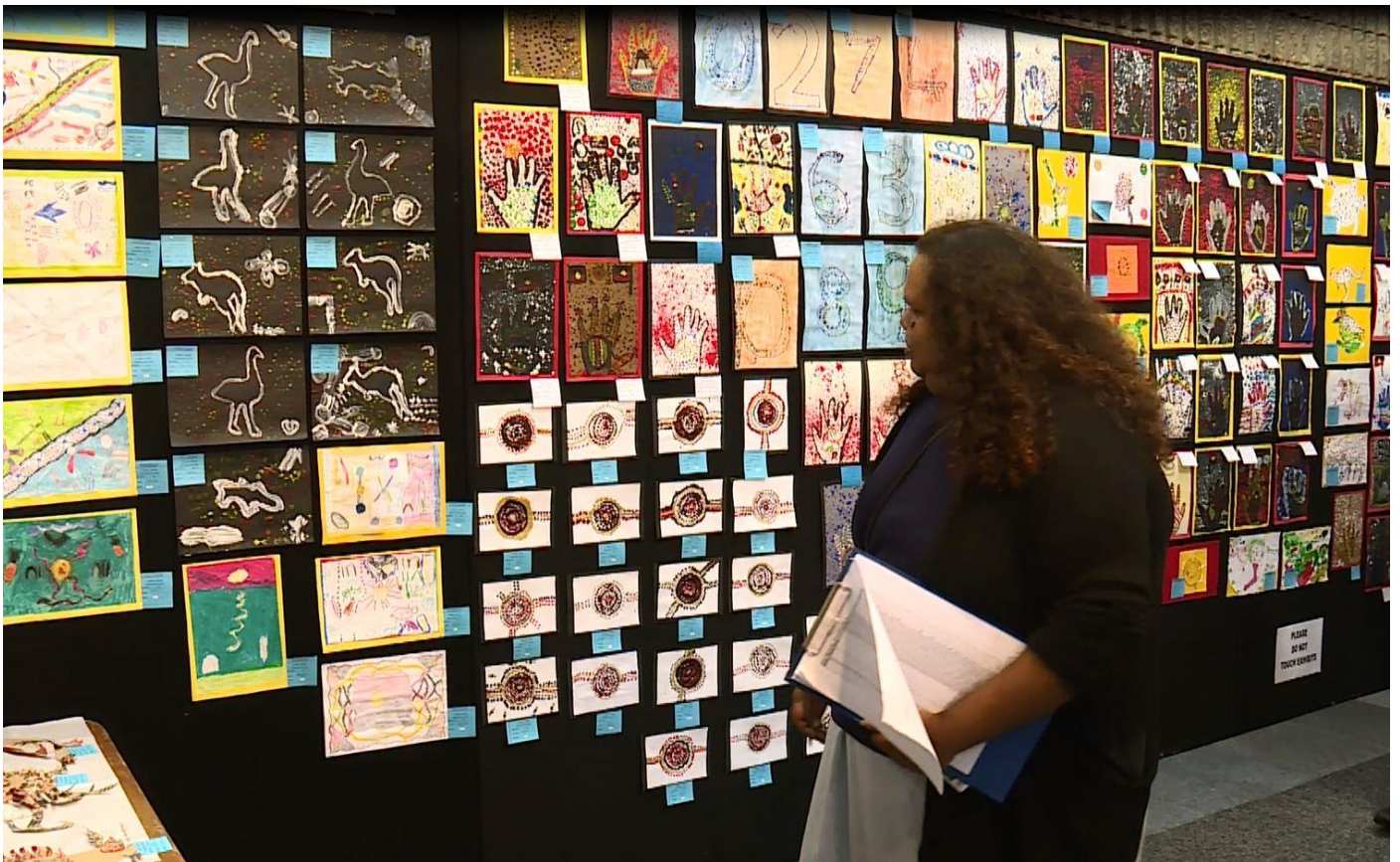

SECTION 23 BBM 98.7 FM INDIGENOUS ARTS**Class 23001 Primary School Years 1-3****Prize:** 1st - \$15 + Sash, 2nd - \$10, 3rd - \$5*Open, Any Medium, Any Subject***Class 23002 Primary School Years 4-6****Prize:** 1st - \$20 + Sash, 2nd - \$15, 3rd - \$8*Open, Any Medium, Any Subject***Class 23003 High School Students to Under 18 Years****Prize:** 1st - \$60 + Sash, 2nd - \$40, 3rd - \$20*Open, Any Medium, Any Subject***Class 23004 Adults****Prize:** 1st - \$100 + Sash, 2nd - \$60, 3rd - \$30*Open, Any Medium, Any Subject*

SPECIAL ANNIVERSARY

Celebrating the 50th Anniversary of NAIDOC.

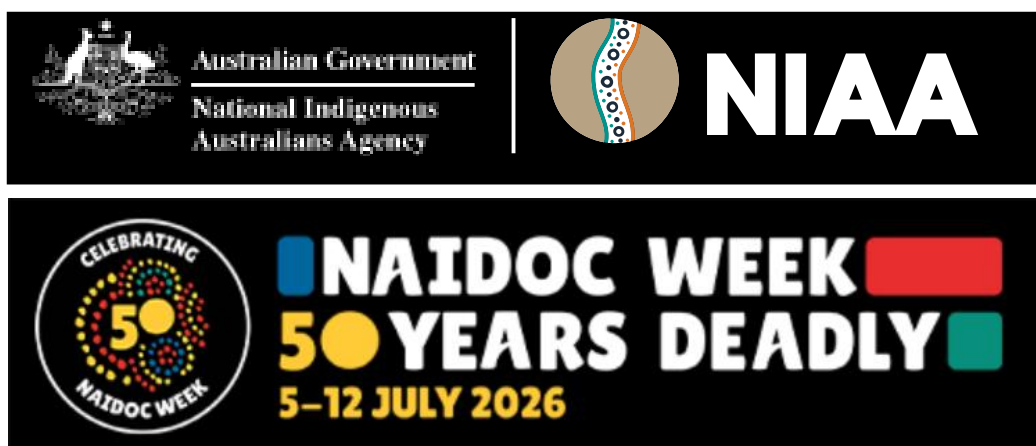

- Class 23005 NAIDOC 150th Anniversary Artwork**
Prize: 1st - \$120 + Sash, 2nd - \$70, 3rd - \$40
Open to all Ages, Any Medium
Artwork must reflect Indigenous culture, heritage, community, storytelling, or the NAIDOC theme.
- Class 23006 NAIDOC Poster**
Prize: 1st - \$100 + Sash, 2nd - \$60, 3rd - \$30
Open to School Students, Any drawing or painting medium.
Poster celebrating Indigenous culture or the NAIDOC theme.
- Class 23007 Indigenous Inspired Craft or Cultural Artwork**
Prize: 1st - \$100 + Sash, 2nd - \$60, 3rd - \$30
Any handmade item inspired by Indigenous culture or storytelling (painting, carving, weaving, mixed media, etc.).

CHAMPION INDIGENOUS ARTWORK OF SHOW - \$150**Prize:** \$150 + Trophy + Sash**PEOPLE'S CHOICE - INDIGENOUS ARTS - \$200****Prize:** \$200 + Trophy + Sash*All entries in the Indigenous Arts section will be eligible for the People's Choice Award.**Visitors to the pavilion may vote for their favourite exhibit. The exhibit receiving the highest number of votes will receive the People's Choice Award.**Voting slips will be available at the pavilion desk.*



**CAIRNS
SHOW**



**15TH - 17TH
JULY 2026**

**SECTION 24
FIBRE CRAFTERS**

SECTION 24 FIBRECRAFTERS

OFFICIALS

Chief Steward: Ms. Carol Coates

KEY INFORMATION

Entry Fee: \$FREE

Prize: 1st - \$15 + Card = 5 Points, 2nd - \$8 + Card = 3 Points, 3rd Card = 1 Point

Entries Close: 4pm **Friday 19th June.**

Delivery of Exhibits: 9am - 4pm **Thursday 9th and Friday 10th July** - Arts & Crafts Hall

Judging: 9am **Saturday 11th July 2026**

Collection of Exhibits: **NOT BEFORE** 10am-12pm **Saturday 18th July** - Main Arena (Centre Ring) side of the Arts & Crafts Pavilion.

By prior arrangement only, out of town exhibitors may collect exhibits after the Fireworks for 30 minutes on **Friday 17th July**

SPONSORS

The Cairns Show Association wishes to record its sincere appreciation to the following Sponsors who have contributed to this area.

Cairns Agricultural, Pastoral and Mining Association, and Fibrecrafters FNQ Inc.

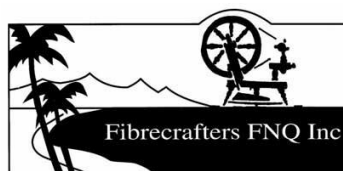
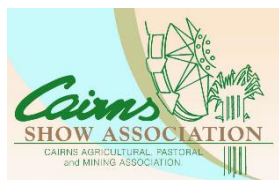

HOW TO ENTER

1. **Complete an Entry online or in person at the Cairns Show Office, or post via PO Box 811 Bungalow, QLD 4870.**
2. Entries will not be accepted over the phone or after the closing date.
3. Pay for Entry Fees online, by direct deposit, or in person at the Cairns Show Office (cash accepted).
4. Entries must be delivered to the designated part of the Showgrounds by the due date time and date shown.
5. Exhibitors will receive Entry and Class Cards.
6. All Class cards are to be placed on the bottom right-hand side of exhibit and small envelope with contact details must be attached to the back of exhibit prior to delivery.

AFTER THE SHOW

- Exhibits not collected by **28th August 2026** will automatically become the property of the Cairns Show Association.
- Prize money under the value of \$50 and Prize Certificates can be collected between 9am and 4pm, Monday to Friday, from Monday 3rd August to **Friday 28th August 2026** from the Show Office.
- Any prize money over the value of \$50 will be directly deposited into your account from Monday **1st August to Friday 28th August.**
- Proof of identity is required to collect Prize Money. If you are collecting prize money on behalf of someone else, a letter of authorization from that person will be required.
- Entrants who have not provided their account details will be contacted via the details presented on their Entry Form.
- ALL Prize Money not collected by 4pm on **Friday 28th August 2026** will be returned to the Cairns Show Association Funds and unable to be collected.
- A 'local' is defined as residing between the areas of Palm Cove & Gordonvale and west to the range.
- Results will be available AFTER the conclusion of the Show from the Cairns Show Website www.cairnsshow.com.au.

SPECIAL REGULATIONS

- Refer to General Conditions of Entry and Competition in front of this Schedule.
- All exhibits must be the sole work of the exhibitors. Exhibits created in tutored workshops are accepted for competition in Class 24025 only.
- Each exhibit may be entered in only one (1) class.
- All exhibits must be completed in the twelve (12) months prior to the 2026 Cairns Show.
- Exhibits entered in previous Cairns Shows are accepted for competition in Class **24024** only and must be reconstructed into an original exhibit different from the one previously judged.
- The Judge reserves the right to alter the Class of an exhibit.
- Exhibits in Classes **24001, 24002, 24003, 24004, 24017** to be accompanied by a completed sample (minimum 10 cm square), mounted on A5 size WHITE heavy card.
- Attach a sample of raw material to exhibits in Classes **24001, 24002, 24003, 24004, 24009, 24010, 24017, 24018, 24019, 24020, 24021 and 24024.**
- Exhibits in class 24022, a joint effort must be accompanied by a description of materials and technique/s used, must reflect the shared work of two (2) or more people and will be judged as one (1) exhibit. Prize-winning joint exhibits will have full points awarded to each participant.
- To assist the Stewards in arranging and dispatching the exhibits after the Show, attach a sealed envelope containing the owner's name and address to the back of each exhibit. Name and address must also be printed on the back of the class cards.
- All exhibits forwarded by mail must include return postage.
- No free passes available to exhibitors.
- Exhibits for sale must be marked clearly with price. Exhibits not for sale must be marked clearly "NFS". Sold items must remain until Saturday of Show.
- Commission of 20% will apply to all exhibits sold and must be included in the sale price. Please liaise with the Chief Steward.

FIBRERAFTERS FNQ INC.

Fibrecrafters FNQ Inc. has been part of the Cairns community since 1980. Originally formed as the Northern Spinners and Weavers, the club began after a group of local craft enthusiasts responded to a radio advertisement inviting people interested in learning and sharing the art of spinning and weaving to meet at the TAFE library.

Later that year the club adopted its constitution and formally established itself, with Sheila Roberson serving as the first President. In 2002 the club became incorporated and later changed its name to Fibrecrafters FNQ Inc. to better reflect the wide range of fibre and textile crafts now practised by its members.

Today, Fibrecrafters FNQ provides a welcoming and supportive environment where members can learn new skills, share knowledge and enjoy the creative arts of spinning, weaving and related crafts. The club promotes the development of high standards in textile crafts while encouraging members to enjoy the social and creative benefits of crafting together.

Members practise a variety of traditional and contemporary fibre arts including spinning, weaving, knitting, crochet, felting, fabric dyeing, bobbin lace, basketry, tapestry weaving and other textile techniques. The club also maintains an extensive library of more than 600 books and DVDs, along with looms, spinning wheels and other equipment available for members to hire.

Located under the Grandstand at the Cairns Showgrounds, Fibrecrafters FNQ welcomes both beginners and experienced crafters. Regular gatherings provide an opportunity to learn new techniques, share ideas and connect with others who enjoy textile crafts.

Visitors are welcome to attend two complimentary sessions, with annual membership available for \$45 per year. Members also contribute to several community initiatives, creating handmade items for Cairns Hospital, cancer patients and other local organisations.

The group meets regularly from 10am–2pm at the Cairns Showgrounds, with a Crochet for Cancer group meeting every second Saturday at the Cairns RSL.

With more than 45 years of crafting and community spirit, Fibrecrafters FNQ continues to play an important role in supporting and promoting fibre arts in the Cairns region.

For more information contact Nikki on 0411 045 880.

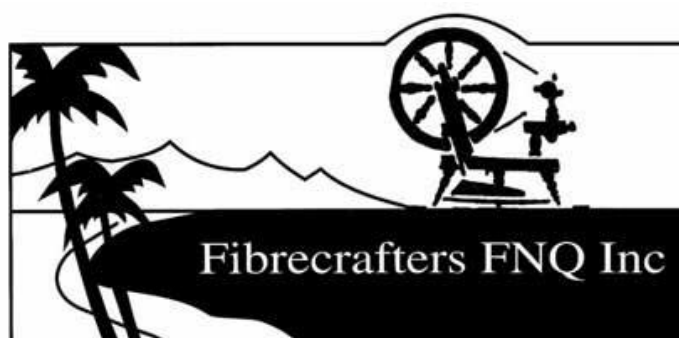

SINGLE EFFORT**SPINNING**

- Class 24001:** Novice - Hand-Spun Yarn
Not more than 3 years' experience, and not previously awarded a prize in classes 24001, 24002, 24003 or 24004. Plied, natural fibre, no blends, 1 skein (minimum 25 metres), washed.
- Class 24002:** Natural Fibre - Hand-Spun Yarn
Natural fibre, no blends, 1 skein (minimum 25 metres), washed.
- Class 24003:** Fibre Blend - Hand-Spun Yarn
Fibre blend, commercial optional, 1 skein (minimum 25 metres), washed.
- Class 24004:** Designer - Hand-Spun Yarn
Hand-Spun Designer Yarn, not less than 25% hand-spun fibre, 1 skein (minimum 25 metres).

DYEING

- Class 24005:** Natural Dyes - Hand-Dyed Yarn
Natural dyes, 1 skein (minimum 25 metres), washed.
- Class 24006:** Commercial Dyes - Hand-Dyed Yarn
Commercial dyes, 1 skein (minimum 25 metres), washed.
- Class 24007:** Natural or Commercial Dyes - Hand-Dyed Article or Garment

WEAVING

- Class 24008:** Hand-Woven Fabric
Any Medium.
- Class 24009:** 100% Hand-Spun Yarn - Hand-Woven Article or Garment
Natural fibre(s).
- Class 24010:** Any Medium - Hand-Woven Article or Garment
- Class 24011:** Hand-Woven Tapestry Weaving
Any Medium framed or unframed, ready to hang.

FELTING

- Class 24012:** Hand-Felted - Wearable Garment or Accessory
Any Techniques - Example: sculpture, bag, shawl.
- Class 24013:** Hand-Felted - Non-Wearable Article
Any Techniques - Example: sculpture, rug, wall piece.
- Class 24014:** Nuno Felted - Wearable Art Garment or Article

SINGLE EFFORT – CONTINUED**BASKETRY**

Class 24015: Hand-Woven Article
Using Basketry Techniques, Any Medium.

Class 24016: Hand-Crafted Basketry or Sculpture
Using Techniques other than weaving, Any Medium - Example: coiling, sewing, wrapping.

OTHER TECHNIQUES

Class 24017: Hand-Crafted Unique Creative Yarn
Using Techniques other than spinning or plying, 1 skein (minimum 25 metres) - Any Medium. Fibre, yarn, fabric, plastic, wire or like material, must be stable for the end use.

Class 24018: Hand-Crafted Article or Sculpture
Using only RECYCLED materials. Example: fabric, plastic, paper. Attached a sample of raw material or photo of a sample of items used in the whole work cannot be obtained. Write a brief description of materials and techniques used.

Class 24019: Lace Item
Any item created from at least two types of lace. Example: hairpin, teneriffe crochet, bobbin, tatting, etc.

Class 24020: Lace Article or Garment
Any Technique (describe briefly) and Any Medium.

Class 24021: Fibrecrafting Techniques - Hand-Crafted Article or Garment
Using a minimum of 3 Fibrecrafting Techniques. Examples: knitting, dyeing, felting, etc. Description of Techniques used and Any Medium.

Class 24022: Knitted or Crocheted from Yarn - Hand-Crafted Article or Garment
Any Article or Garment knitted or crocheted from any yarn (including natural or synthetic fibres, hand or commercial spun).

JOINT EFFORT

Class 24023: Hand-Crafted Article or Garment/ Other
Any Technique/s, Any Medium, Any Other Article.

ANY OTHER ARTICLE

Class 24024: Original Article Reconstructed
From a previous judged article. See Special Regulation 5.

Class 24025: Any Other Article Not Specified

SPECIAL CLASS

Class 24026: Finished - Hand-Crafted Yarn, Article or Garment Created in a Tutored Work
Using Fibrecrafting Techniques with any fabric, material or yarn (if applicable, 1 skein minimum 25 metres) This is open to all workshop attendees, not just those convened by Fibrecrafters FNQ Inc.

AWARD FOR EXCELLENCE - \$50 GIFT VOUCHER

Most points overall in classes 24001 to 24026

Prize: \$50 Gift Voucher + Sheila Robertson Perpetual Trophy + Sash

Sponsored by Fibrecrafters FNQ Inc.

AWARD FOR EFFORT - \$50

This Award encourages diversity of talents. An exhibitor who has entered a minimum of five classes from 24001 to 24026 and earns the highest points other than Award for Excellence recipient.

Judge's decision if tied points or if no one qualifies.

Prize: \$50 + Gladys & Ray Brown Perpetual Trophy + Sash

JUDGES AWARD - \$50

Awarded to the Judge's choice of one exhibit in Classes 24001 to 24026

Prize: \$50 + Sash



ART WORKS
FOR SALE



SECTION 25 VISUAL ARTS

OFFICIALS

Chief Steward:	Mrs. Lone White
Steward:	Mrs. Christina George
3D Section Judge:	Ms. Hilary Tredgett
2D Section Judge:	Ms. Judy Brady
Children's Section Judge:	Mr. Lesley Graf

KEY INFORMATION

Entry Fee: *As Stated.*

Prize: *As Stated + Card.*

Entries Close: 4pm **Friday 19th June.**

Delivery of Exhibits: 12pm-6pm **Wednesday 8th July** - Visual Arts Hall, at the back of and under David Headrick Grandstand opposite Mulgrave Rd.

Judging: 10am **Sunday 12th July**

Collection of Exhibits: 9am-12pm **Saturday 18th July.** No responsibility will be taken for any exhibits left after this time. Exhibits not collected by **Friday 28th August** will become Property of the Cairns Show Association unless otherwise arranged prior to the conclusion of the Cairns Show.

SPONSORS

The Cairns Show Association wishes to record its sincere appreciation to the following Sponsors who have contributed to this area.

Cairns Agricultural, Pastoral and Mining Association, Cairns Potters Club, Cairns Art Society, and Showbag Warehouse

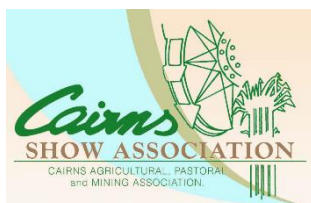

HOW TO ENTER

1. Complete an Entry online or in person at the Cairns Show Office, or post via PO Box 811 Bungalow, QLD 4870.
2. Entries will not be accepted over the phone or after the closing date.
3. Pay for Entry Fees online, by direct deposit, or in person at the Cairns Show Office (cash accepted).
4. Entries must be delivered to the designated part of the Showgrounds by the due date time and date shown.
5. Exhibit (Class) Cards will be posted or given to the Entrant after the entry closing date or may be collected from the Cairns Show Office by prior arrangement.

SECTION 25 VISUAL ARTS

AFTER THE SHOW

- Exhibits not collected by **28th August 2026** will automatically become the property of the Cairns Show Association.
- Prize money under the value of \$50 and Prize Certificates can be collected between 9am and 4pm, Monday to Friday, from Monday **1st August to Friday 28th August 2026** from the Show Office.
- Any prize money over the value of \$50 will be directly deposited to your account from Monday **2nd August to Friday 28th August**.
- Proof of identity is required to collect Prize Money. If you are collecting prize money on behalf of someone else, a letter of authorization from that person will be required.
- Entrants who have not provided their account details will be contacted via the details presented on their Entry Form.
- ALL Prize Money not collected by 4pm on **Friday 28th August 2026** will be returned to the Cairns Show Association Funds and unable to be collected.
- A 'local' is defined as residing between the areas of Palm Cove & Gordonvale and west to the range.
- Results will be available AFTER the conclusion of the Show from the Cairns Show Website www.cairnsshow.com.au.

SPECIAL REGULATIONS

- **Each artist is restricted to a maximum of four (4) entries overall.**
- **Each artist is restricted to a maximum of two (2) entries per class including Sculpture and Pottery.**
- All exhibits must be the original and unaided work of the exhibitor.
- All exhibits must have been executed within the last twelve (12) months prior to the 2026 Cairns Show. Previous Cairns Show exhibits will not be accepted.
- No exhibit can be entered into more than one class.
- **All two-dimensional work to be suitably framed and/or presented, securely wired ready for hanging and no larger than 100cm x 100cm. Oversized work and work not able to be hung will be rejected.**
- **Junior two-dimensional works are to be completed on card stock of A4 size, except Classes 25017 - 25022.**
- **All exhibits must be clearly marked on the back/base with the exhibitor's name, address, price and whether it is for sale. Exhibits not marked will be classed as not for sale. Commission of 25% will apply to all exhibits sold and must be included in the Sale Price. Stewards will advise artists of people interested in their artwork.**
- **Class cards must be attached, on 2D work attach on back, right hand side, allowing to hang and be seen from the front.**
- All exhibits forwarded by mail should be securely packed and arrangements made for return. No costs shall be incurred by the Cairns Show or their Agents.
- Exhibitors shall allow their works to be photographed or reproduced for press and television during the exhibition period.
- No exhibits are to be removed from the Cairns Showgrounds prior to 9.00am **21st July 2026**.
- All exhibits **MUST** be collected between 9:00am and 12:00pm on **21st July 2026**. No entry will be permitted to be removed before this time. Exhibits must be signed by a steward (**If you are unable to comply - Do Not Enter**).
- No responsibility will be taken for any exhibits left in the grandstand area after this time. If not collected, the exhibit will become Property of the Cairns Show Association unless otherwise arranged.
- All entries must be signed upon arrival and signed out by a steward at collection.
- No free passes available to exhibitors.
- All exhibits are to be delivered to the Visual Arts Hall at the back of the Headrick Grandstand at the times stated. No late entries will be accepted whatsoever. Chief Steward's decision will be final.
- All people upon entering any class in this Schedule agree to indemnify the Cairns Agricultural Pastoral and Mining Association against liability for any accident, damage, loss or illness to any Exhibit, Exhibitor or Competitor and agree that all Competitions are under the complete and total control of the Cairns Agricultural Pastoral and Mining Association whose decision in all matters is final.
- The Cairns Agricultural Pastoral and Mining Association:
 - Will appoint a Chief Steward to each Section as its representative in all matters
 - Will appoint Judges whose decision is final, and
 - Reserves the right to make any decisions, inclusions or changes to this schedule including Conditions of Entry and Competition without further notice.



OPEN**PAINTINGS****Entry Fee:** \$2.50**Prize:** 1st - \$65, 2nd - \$20**Class 25001:** Oils**Class 25002:** Acrylics**Class 25003:** Mixed Media**Class 25004:** Watercolour**Class 25005:** Graphic - Charcoal, Pen, Pencil, Conte, etc.**Class 25006:** Digital Art**CHAMPION 2-DIMENSIONAL ARTWORK OF SHOW - \$100****Prize:** \$100 + Sash**SCULPTURE****Entry Fee:** \$2.50**Prize:** 1st - \$65, 2nd - \$20**Class 25007:** Sculpture**POTTERY****Entry Fee:** \$2.50**Prize:** 1st - \$65, 2nd - \$20**Class 25008:** Pottery - Open**Class 25009:** Pottery - Novice*Less Than 3 Years Experience and Not a Previous Winner***CHAMPION 3-DIMENSIONAL ARTWORK OF SHOW - \$100****Prize:** \$100 + Sash

QUEENSLAND HERITAGE REGISTER

Entry Fee: \$FREE

Prize: 1st - \$100, 2nd - \$50

The Queensland Heritage Register is a list of places that have cultural heritage significance to the people of Queensland showing the pattern of Queensland's history and regional development. They illustrate incredible human endeavours political, social and cultural forces that have shaped our society. Accordingly, places are protected under heritage legislation. Whilst any State Heritage Place may be the subject of this visual arts category, it is expected that interest will be mostly on those State Heritage Places located in the Cairns region.

A Selection of Heritage-Registered Locations in the Cairns Region:

- | | |
|---|--|
| <ol style="list-style-type: none"> 1. Cairns Court House Complex 2. Cairns Customs House (former) 3. Cairns City Council Chambers 4. Cairns Masonic Temple 5. Cairns War Memorial 6. School of Arts, Cairns (former) 7. Mulgrave Shire Council Chambers (former) 8. Cairns Technical College and High School Building 9. Hides Hotel 10. McLeod Street Pioneer Cemetery 11. Cairns Wharf Complex 12. Cairns Plywood Pty Ltd Sawmill Complex 13. World War II Volunteer Defence Corps, Cairns Control Room 14. Cairns Railway, Section from Redlynch to Crooked Creek Bridge | <ol style="list-style-type: none"> 15. Cross Terrace 16. Flecker Botanical Gardens 17. Central Court 18. Bishop's House 19. Adelaide Steamship Co Ltd (former) 20. St. Joseph's Convent 21. Barrier Reef Hotel 22. St. Monica's Old Cathedral 23. Dr. EA Koch Memorial 24. St. Monica's High School Administration Building 25. Herries Private Hospital 26. Bolands Centre 27. Explosives Magazine and Detonator Store (former) 28. 16 Heavey Crescent, Whitfield |
|---|--|

You can find more at [Queensland Government Heritage Register](https://www.qld.gov.au/heritage/register).

This category is sponsored by the Heritage Council, the State's independent advisor on heritage matters. The Heritage Council determines what places are entered in the Queensland Heritage Register.

Class 25010: State Heritage Places entered in the Queensland Heritage Register
Visual Arts, Any Medium.

JUNIOR**SCULPTURE****Entry Fee:** \$1**Prize:** 1st - \$10, 2nd - \$5, 3rd - \$2**Class 25011:** Sculpture - 12 Years & Under**Class 25012:** Sculpture - 13 Years to Under 18 Years**VISUAL ARTS****Requirements for the classes below age groups 5 Years and Under, and 6-10 Years:**

- Must be presented unframed and mounted on A4 Card Stock (21cm x 30cm).
- Canvas is accepted.
- Limit One (1) Entry per artist, per class.

Requirements for the classes below age groups 11-13 Years, and 14 to Under 18 Years:

- Canvas and Framed Exhibits (securely wired ready for hanging) are accepted in this age group only.
- Maximum size is 60cm x 60cm. Exhibits of this size are not accepted.
- Students can present their work unframed and mounted on A4 card stock (21cm x 30cm).
- Limit One (1) Entry per artist, per class.
- Printmaking entries can be up to A3 size.

5 YEARS & UNDER**Entry Fee:** \$1**Prize:** 1st - \$8, 2nd - \$4, 3rd - \$2**Class 25013:** Oils, Watercolour, Acrylic
*Any Subject***Class 25014:** Drawing
*Pencil, Felt Pen, Crayon, Coloured Pencil, Biro - Any Subject.***6 - 10 YEARS****Entry Fee:** \$1**Prize:** 1st - \$12, 2nd - \$8, 3rd - \$5**Class 25015:** Oil, Watercolour, Acrylic
*Any Subject***Class 25016:** Drawing
Pencil, Felt Pen, Crayon, Coloured Pencil, Biro - Any Subject

JUNIOR – CONTINUED**11 - 13 YEARS****Entry Fee:** \$1**Prize:** 1st - \$15, 2nd - \$12, 3rd - \$8**Class 25017:** Oil, Watercolour, Acrylic
*Any Subject***Class 25018:** Drawing
*Pencil, Felt Pen, Crayon, Coloured Pencil, Biro - Any Subject***Class 25019:** Mixed Media & Printmaking
*Any Subject***14 - UNDER 18 YEARS****Entry Fee:** \$1**Prize:** 1st - \$18, 2nd - \$15, 3rd - \$12**Class 25020:** Oil, Watercolour, Acrylic
*Any Subject***Class 25021:** Drawing
*Pencil, Felt Pen, Crayon, Coloured Pencil, Biro - Any Subject***Class 25022:** Mixed Media & Printmaking
*Any Subject***CHAMPION JUNIOR ARTWORK OF SHOW - \$25****Prize:** \$25 + Sash

SPECIAL NEEDS

Entry Fee: \$1

Prize: 1st - \$18, 2nd - \$15, 3rd - \$12

Requirements for the classes below:

- Canvas and frame exhibits (securely wired ready for hanging) are accepted in special needs.
- Maximum size is 60cm x 40cm. Exhibits of this size are not accepted.
- Artists can also present their work unframed and mounted on A4 card stock (21cm x 30cm).
- Limit One (1) Entry per artist, per class.

Class 25023: Oil, Watercolour, Acrylic
Any Subject

Class 25024: Drawing
Pencil, Felt Pen, Crayon, Coloured Pencil, Biro - Any Subject

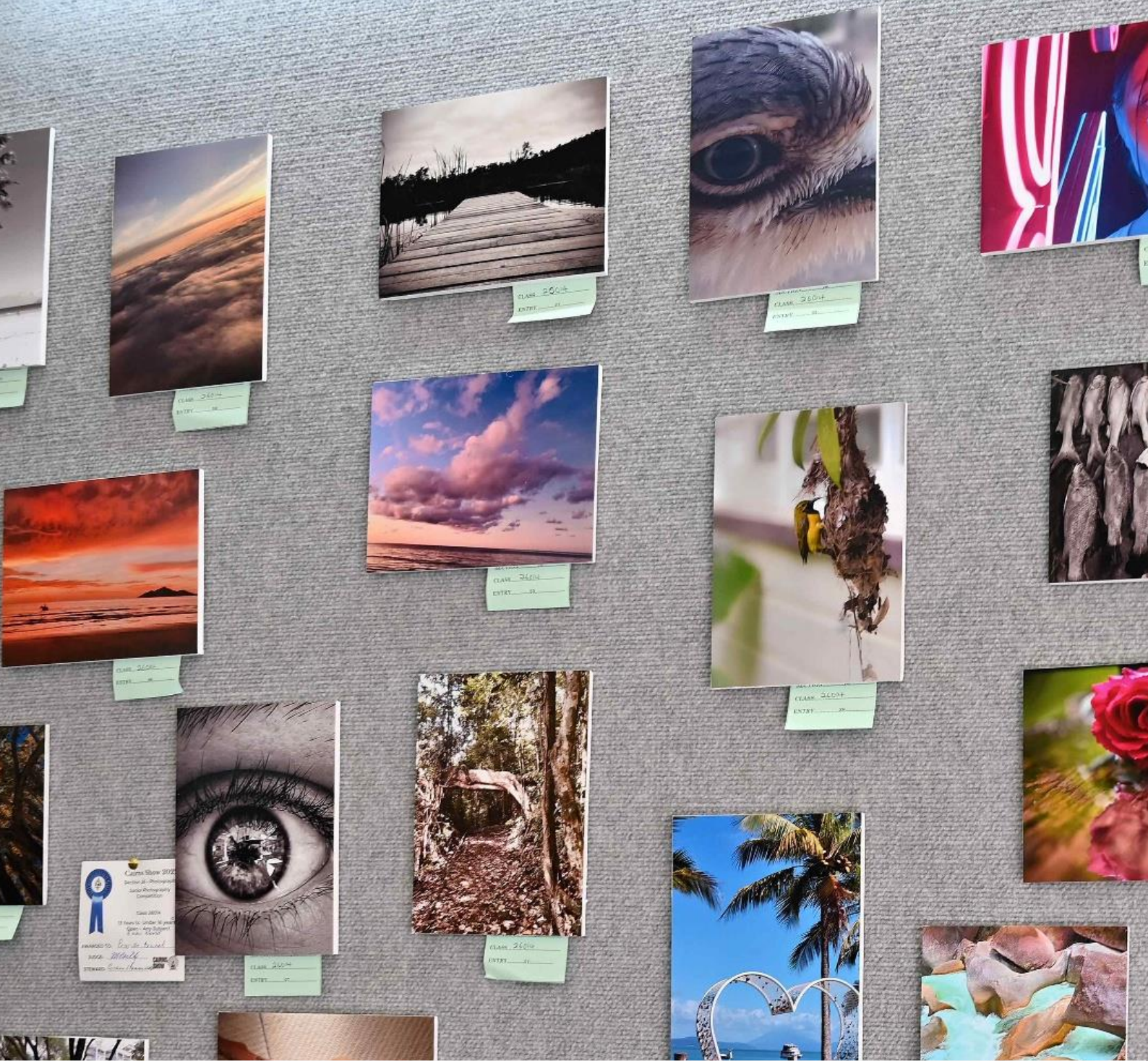

**CAIRNS
SHOW**



**15TH - 17TH
JULY 2026**

**SECTION 26
PHOTOGRAPHY**



SECTION 26 PHOTOGRAPHY

OFFICIALS

Chief Steward: Richard Foord

Stewards: Members of the Cairns Photographic Society Inc.

KEY INFORMATION

Entry Fee: \$5.00 for Open Classes, Free for Junior Classes.

Prize: As Stated in Schedule.

Entries Close: 4pm **Friday 19th June.**

Delivery of Exhibits: 12pm - 6pm **Wednesday 8th July** - back of Dave Headrick Grandstand.

Judging: 10am - 4pm **Sunday 12th July.**

Exhibit Collection: 9am - 11am **Saturday 18th July** - back of Dave Headrick Grandstand.

SPONSORS

The Cairns Show Association wishes to record its sincere appreciation to the following Sponsors who have contributed to this area.

Cairns Agricultural, Pastoral and Mining Association, Cairns Photographic Society, Garricks Camera House, Tim Warnock, and Cairns Private Hospital.

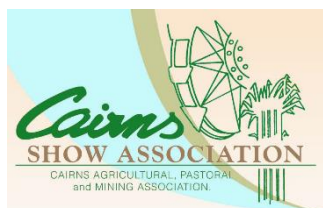

SECTION 26 PHOTOGRAPHY

DELIVERING THE PRINTS

- Mounting and presentation of your photos form an important part of the judging.
- Exhibits must be delivered to the Photography Room in the Dave Headrick Grandstand by the due time and date shown.
- Whoever delivers your images must also present a copy of your entry receipt (printed or digital) at this time.
- All entries must be presented fully mounted and ready for hanging. Any images that are not ready to be hung may be rejected.
- Follow the details on sizing, mounting, display and labelling images in the Special Regulations set below.
- Results will be published after the Show has concluded on the website.

AFTER THE SHOW

1. All prints should be collected from the Dave Headrick Grandstand on **Saturday 18th July** between 9am and 11am.
2. If it is not possible to collect the prints on the Saturday, prints can be collected at the Cairns Show Office from 20th July. Prints not collected by **28th August 2026** will automatically become the property of the Cairns Show Association.
3. Prize Money can be collected between 9am and 4pm Monday to Friday **1st August to 28th August 2026** from the Show Office if your total prize money is less than \$50.
4. Proof of identity is required to collect Prize Money. If you are collecting prize money on behalf of someone else, a letter of authorisation from that person will be required.
5. All Prize Money less than \$50 not collected by 29th August, 4pm will be returned to the Cairns Show Association Funds.
6. Prize money of \$50 and over will be deposited to the entrant's nominated bank account after **28th August**.
7. No Free passes are available to entrants.

SPECIAL REGULATIONS

Please refer to **General Conditions of Entry & Competition in front of Arts & Crafts Schedule for overriding conditions.**

• **IMAGE SOURCE AND EDITING**

- All images must be the original unaided work of the entrant (Commercial processing of the physical print is accepted in all classes).
- There is no limit on the date the photograph was taken.
- An image that has won a prize in previous Cairns Shows is not eligible for entry.
- The image may be taken with any camera, drone, phone or tablet camera.
- All images and image components used in the Creative / Experimental and Special Subject Theme classes must be created and owned by the entrant

• **EDITING OF IMAGES**

- Editing of images using photographic software such as Photoshop, Lightroom, Luminar and phone filters etc. is permitted to enhance the image to achieve the photographer's vision. (All classes)
- Each image must be of a single image and may be treated with HDR, focus stacking, exposure bracketing, long exposure techniques, in-camera multiple exposure, but not by the merging of layers containing the same image taken at significantly different times. (All classes except Creative/Experimental, Open Special Theme and Junior Special Subject)
- The elimination of objects through cloning or healing is accepted, and the use of "content-aware" fill technology is permitted where the fill content directly blends with the image and does not add additional elements not originally present in the image. (All classes)

• The addition of elements from third party sources is not permitted including (all classes):

- Components and images generated by AI or similar tools or technology.
- Elements sourced from third party sources such as stock photography, internet sites etc.
- Non-photographic elements such as graphics, text or clip art etc.
- Specific digital drawing elements (note that techniques such as custom 'brushes' can be used).

• **ENTRY LIMITATIONS AND CLASSES**

- Class definitions and guidelines are important so should be read carefully
- Maximum of 10 (ten) images per entrant with a limit of 3 (three) images per entrant for the junior section.
- An image can only be entered in one class.
- Junior entrants may enter images in both sections but no more than 10 (ten) entries in total
 - Any image can only be entered into one class regardless of section.
 - No more than 3 (three) entries can be entered in the Junior Sections in total, leaving up to an additional 7 (seven) entries available for the Open Section.
- At the discretion of the Chief Steward, an image may be moved out of one category into another, if deemed to be an incorrect fit for the entered category.
- Entries must not include any watermarks, signatures, logos, advertising, web addresses, entrant's name etc on the displayed image or front mounting materials.

SPECIAL REGULATIONS

• PRESENTATION AND MOUNTING

- Mounting and presentation of your photos form an important part of the judging.
- Mounting on standard adhesive foam-core board (3mm-5mm) that comes in ready-cut A4 and A3 sizes represents one of the most cost effective and readily available techniques.
- Alternatively - Images must be mounted on heavy stiff cardboard - ideally 600+gsm. This is required to ensure your image does not warp in the humidity and/or fall off the wall. Other mounting materials including, but not limited to, acrylic, glass, wood, canvas or metal are not permitted.
- Mattes and cardboard frames can be on the front to frame the image (ensuring the total entry is no larger than the size limited below) and can be any colour, but generally black mattes / mounts for this type of competition are best.
- Image thickness should not exceed 6mm.
- **There MUST be at least 4 Velcro dots (HOOK side) on each corner of the back of the mounting frame.** This allows the images to be mounted on the to the carpet-like material used on the walls.
- Commercial services may be used to create the print and mount.
- Write your Entry Number, Class Entered, Name, and an Image Title on the back of the image. The image title can be descriptive (i.e. Purple Flower) or subjective (i.e. Bloom of Life)
- All Junior Section entries must also include the Entrant's School on the back of the image. This is important as prizes also go to schools as well as the entrant for the Junior Section
- Class Cards will be provided and attached to the image when you deliver your image to the show grounds.

• IMAGE SIZES

- **Open Section:**
 - The final image plus it's mount must fit within a 41cm x 30.5cm (16"x12") area OR be no larger than a single A3 sheet of paper (42cm x 29.7cm).
 - Therefore, if you have a square image, it may not be larger than 30.5cm x 30.5cm (12"x12").
 - The actual image must not be smaller than 20cm x 15cm (8"x6"). Therefore, if you have a square image, it must be at least 8"x8".
 - The image plus its mount is not smaller than 25cm x 20cm (10"x8"). (This means if your image is the smallest possible size, you must have a border/mat of at least 2.5cm thickness around the edge).
- **Junior Section:**
 - The maximum size of an entry, the image and any included "framing", must not exceed 29.7cm x 21cm (the size of an A4 piece of paper).
 - The size of each image must not be smaller than 15cm x 10cm (6"x4").

CLASS DEFINITIONS

- **PEOPLE/PORTRAITURE:**

- A Photograph of a person or persons that may range from a head study to full body length. This section includes candid photographs and formal portraits. This category is for photographs where people are the focus whether a single person or a group, showing the human aspect of life in all its wonderful variety. From self-portraits as an expression of the photographer, or portrait images capturing the personality of a person or group of people interacting. Images from events where the interaction of the people is central, or street and ad-hoc portraiture which capture the essence of lifestyle, random moments, real life, chance encounters.
- The person/people/interaction is central to the subject, not the activity or surroundings.

- **SCAPES:**

- In the monochrome section there is a single class combining both styles of images described below.
- Landscape and seascape photography is capturing an image that embodies the spirit of the outdoors. It carries a sense of being there to see something incredible. The image may contain people or man-made objects that provide perspective or highlight the grandeur of the landscape. These man-made elements may also balance the image or enhance the sense of calm, danger, action, isolation etc. of the landscape while remaining incidental to the core story.
- Urban and streetscape photography records the true state of the human condition by showing how society acts when it thinks that nobody is watching. Streetscapes can show the harsh geometry of man-made structures AND/OR contrast them around contradictory natural objects. They will often show the intense crowding of high-density living or the desolation of abandoned or empty streets. They include shapes, patterns, reflections found commonly in the man-made world and the actions and interactions of life and living in an environment that is distinctly human made and both positive and negative sides of the human-urban condition. Streetscapes may often include people and man-made objects where the focus is the scape and the urban environment over the individuals or the activity inside the scape.
- Close-up features are NOT regarded as landscapes.

- **ACTION / SPORTS:**

- Images that emphasize sports or personal pursuits that involve and portray a high energy environment. They can show a moment in time, a particular active event or portray the artistry / symmetry of moment in time of participation. These shots either catch a clear frozen moment or rather imply the blur of rapid movement. The viewer is clearly in awe of activity and the participant.

- **THE NATURAL KINGDOM:**

- Includes birds, insects, animals, reptiles and fishes and including animals of a domestic nature provided no evidence of restrictions or caging or fencing is evident.
- This includes plants and/or flowers through any stage of the life cycle, from seed to decay. This includes bark, leaves, fungi, as well as flowers, seeds and grass. Subjects may be cultivated or uncultivated.

CLASS DEFINITIONS

- **SPECIAL TECHNIQUE – SLOW SHUTTER SPEED PHOTOGRAPHY :**

- This class will change from year to year and focuses on a particular technical aspect or type of photography. For 2026, the opportunity is to showcase images taken of the smaller aspects of life.
- The “Slow Shutter” theme celebrates the creative use of long exposure techniques to capture motion, light trails, and temporal effects.
- Photographers are encouraged to explore:
 - Motion blur to convey movement (e.g., flowing water, moving vehicles, crowds)
 - Light trails from traffic, fireworks, or illuminated objects
 - Night photography and low-light scenes with extended exposure
 - Panning of moving cars, cyclists etc. to emphasize movement past a background.
 - Softening seascapes with water and/or cloud movement.
- Standard editing techniques in the editing guidelines as outlined are allowed (i.e. saturation contrast, clarity etc.) but not any techniques that fall into the Creative/Experimental section.

- **ANNUAL THEME – CELEBRATIONS:**

- This class is a subjective theme that will change from year to year and challenges the photographer to capture an image that evokes a story with a theme.
- The theme may be taken literally OR may also be taken figuratively.
- Being the 150th year since the founding of "Cairns" we invite you to enter images depicting celebrations of all types, birthdays, weddings, events, competitions or just life !! etc.
- This class can include creative editing techniques and such as composite editing similar to that allowed in Creative / Experimental where the outcome represents the subject in the eyes of the judges. Following all the requirements of a creative section – all components must be the work of the entrant.

- **OPEN:**

- Any subject created pictorially where the image has the key elements of design, arrangement, composition and wow.
- A reflection of the photographer’s interpretation and can include direct or abstract concepts, minimalism, shape studies etc.

- **CREATIVE / EXPERIMENTAL:**

- Creative or experimental photographs display a novel effect because of an unusual combination of objects and/or unusual viewpoint. Images may consist of composite of multiple photographs and that have been modified during or after exposure.
- Images may also include the use of an elaborate set or make-up to portray a surreal or unreal situation. Resulting images may be the result of combining multiple images taken by the photographer. Creativity and innovation in the construction of the image and its elements may include editing through the use of software or the mere application of creative studio lighting or in camera techniques.
- All components of the image must be the property of the photographer.
- Creative or experimental photographs may be Colour or Monochrome.

CLASS DEFINITIONS

- **JUNIOR CLASSES:**

- Junior Classes:
 - For '12 Years of Age and Under - Open - Any Subject', and '13 Years to Under 18 Years - Open - Any Subject' should follow the guidelines above for "Open" with editing allowed as per the guidelines under Image Source and Editing.
- The Junior Special Subject class can follow the extended editing outlines available to Creative/Experimental as noted above. Taking note of not adding components, into the final image, that are not created by the entrant, come from the general internet, general web picture or tool libraries or generated by AI tools.

OPEN SECTION – MONOCHROME

Any photograph containing shades of only one colour. If toning is carried out, it must be over the total photograph. Any image containing partial toning and/or the addition of one extra colour is not acceptable in a monochrome class.

Any image determined to not meet the definition of monochrome may be moved to a corresponding class in the Colour and Combined section at the discretion of the Chief Steward.

Entry Fee: \$5.00

Prize: 1st - \$40.00, 2nd - \$20.00, 3rd - \$10.00

Class 26001 Monochrome - People

Class 26002 Monochrome - Scapes

Class 26003 Monochrome - Open

CHAMPION MONOCHROME PRINT

Prize: Battery World Perpetual Trophy + Sash



OPEN SECTION – COLOUR & COMBINED

All classes in this section may contain full colour OR monochrome images. At the discretion of the Chief Steward, a monochrome image that is submitted in a class may be moved to the specific monochrome section where this is more applicable.

Any image presented in this section that is rendered in Monochrome will still be considered to be eligible for the Champion Monochrome Print.

Entry Fee: \$5.00

Prize: 1st - \$40.00, 2nd - \$20.00, 3rd - \$10.00

Class 26004: Colour - People

Class 26005: Colour - Land & Sea Scapes

Class 26006: Colour - Urban & Street Scapes

Class 26007: Action / Sports

Class 26008: The Natural Kingdom

Class 26009: Special Technique - Slow Shutter Speed Photography

OPEN SECTION – COLOUR & COMBINED

Class 26010: Annual Theme - Celebrations

Class 26011: Open

Class 26012: Creative / Experimental

CHAMPION COLOUR PRINT

Prize: Dawsons Engineering Perpetual Trophy + Sash

RESERVE GRAND CHAMPION IMAGE OF SHOW - \$150

Prize: Sash

Sponsored by...

Selected by judges between Champion Colour Print & Champion Monochrome Print.

GRAND CHAMPION IMAGE OF SHOW - \$350

Prize: The Cairns Photographic Society Inc Perpetual Trophy + Sash

Sponsored by...

Selected by judges between Champion Colour Print & Champion Monochrome Print.

CHAMPION PHOTOGRAPHER OF SHOW

Prize: The Cairns Photographic Society Inc Perpetual Trophy + Sash

Awarded to the Exhibitor who gains the most Aggregate Points, overall, in the Photography Section

Points awarded as follows:

For each Open Class: First - 3 points, Second - 2 points, Third - 1 point.

Champion Monochrome Print, Champion Colour Print: 5 points



JUNIOR SECTION

Entry Fee: Free

Prizes: 1st - \$30 + Ribbon, 2nd - \$15 + Ribbon, 3rd - \$10 + Ribbon

Class 26013: 12 Years of Age and Under - Open - Any Subject

SCHOOL AWARD - FIRST PLACE STUDENT - 12 YEARS & UNDER - \$200

Awarded to the nominated school of the student with the first-placed print

Class 26014: 13 Years to Under 18 Years - Open - Any Subject

SCHOOL AWARD - FIRST PLACE STUDENT - 13 YEAR TO UNDER 18 YEARS - \$200

Awarded to the nominated school of the student with the first-placed print

Class 26015: Special Subject: My Tropical Home - Open All Ages Under 18 Years

This class is open to All Ages in the Junior Section (under 18 years old)

Create an image that you believe encapsulates both the sense of Home as well as The Tropics and/or our Tropical Surroundings or Climate.

Cairns is a beautiful location and the rugged beauty of the gulf to the Torres Strait islands as well as the temperature, storms and humidity all play a factor in defining our home lives in the tropical climate and can result in some wonderful displays of home life in the North.

GARRICKS CAMERA HOUSE AWARD

Prize: Garricks Camera House 18"x24" Canvas Print Voucher

Awarded to the individual of First Placed Print in the Junior Open Class – Class 26015





**CAIRNS
SHOW**



**15TH - 17TH
JULY 2026**

**SECTION 27
CRAFT &
NEEDLEWORK**

SECTION 27 CRAFT & NEEDLEWORK

OFFICIALS:

Chief Steward: Ms. Carol Coates

Steward: Ms. Mary Mattson, Mrs. Jan Anderson, & Mrs. Sandra Bawden

KEY INFORMATION:

Entry Fee: \$FREE

Prize: 1st - \$8 + Card, 2nd - \$4 + Card, 3rd - Card, Highly Commended Card - *unless otherwise stated*

Entries Close: 4pm **Friday 19th June**. Entries on the day of Delivery may be accepted.

Delivery of Exhibits: 9am-4pm **Thursday 9th July** and **Friday 10th July** - WIN News Arts & Crafts Pavilion (underneath De Jarlais Function Centre).

Competition Lapidary must be taken to the Fred Moule Exhibition Centre (refer to Sub Section for notes).

Judging: 9am **Saturday 11th July**.

Collection of Exhibits: **NOT BEFORE** 10am-2pm **Saturday 18th July** - Main Arena (Centre Ring) side of Arts & Crafts Hall.

SPONSORS:

The Cairns Show Association wishes to record its sincere appreciation to the following Sponsors who have contributed to this area.

Cairns Agricultural, Pastoral and Mining Association, Channel 9 WIN News, Showbag Warehouse, ORN Alterations, Dream Sewing Supplies and Cairns Needle at Work.



HOW TO ENTER:

1. Complete an Entry online or in person at the Cairns Show Office, or post via PO Box 811 Bungalow, QLD 4870.
2. Entries will not be accepted over the phone. Entries may be accepted on the day of Delivery.
3. Entries must be delivered to the designated part of the Showgrounds by the due date time and date shown.

AFTER THE SHOW:

- Exhibits NOT collected by **Friday 28th August 2026** will become Property of the Cairns Show Association.
- Prize Money can be collected between 9am and 4pm Monday to **Friday 1st August to 28th August** from the Show Office if your total prize money is less than \$50.
- Proof of identity is required to collect Prize Money. If you are collecting prize money on behalf of someone else, a letter of authorisation from that person will be required.
- All Prize Money less than \$50 not collected by **29th August, 4pm 2026** will be returned to the Cairns Show Association Funds.
- Prize money of \$50 and over will be deposited to the entrant's nominated bank account after **28th August**. Please ensure you have provided your bank details to the Cairns Show Office. If you have not, a staff member will contact you via email.
- Results will be available from the [Cairns Show website](#) AFTER the conclusion of the Show.

SPECIAL REGULATIONS

- Refer General Conditions of Entry and Competition in front of this Schedule.
- All exhibits must be the original and unaided work of the exhibitor. Factory made articles are not allowed in this Section.
- No exhibit can be entered into more than one class.
- All exhibits in Junior Classes must be nominated under their name, signed by an adult and include date of birth on entry form.
- All exhibits must have been executed/completed within the last twelve (12) months prior to the 2026 Cairns Show.
- To assist the Stewards in arranging and dispatching exhibits after the Show, a small, sealed envelope containing name and address of owner must be securely attached to the back of each exhibit.
- Please attach Class Card to the back, bottom right-hand side of the exhibit, the class card must be visible.
- Name and address or contact number must also be at the back of the Class Card.
- All exhibits forwarded by mail must include return postage. The Cairns Show Association takes absolutely no responsibility for items forwarded by mail.
- No person other than Judges, Chief Steward and Stewards to be present while Judging is taking place. Arts & Crafts Pavilion will be locked during Judging.
- The Judge reserves the right to alter the Class of an exhibit.
- Out of town exhibitors may collect exhibits AFTER the fireworks for 30 minutes on Friday Night **17th July 2026**. Prior arrangements must be made with Chief Steward.
- In the event of an exhibit in any one class not being worthy of a prize, no prize money will be awarded.
- Please deliver items between 9am - 4pm on **Thursday 9th** and **Friday 10th July 2026**.
- Exhibits may be collected from 10am to 2pm on **Saturday 18th July 2026** from The Arts and Crafts Hall - Ring Side (underneath the De Jarlais Function Centre at the Showgrounds).
- No responsibility will be taken for exhibits left in the Arts & Crafts Hall after this time.
- No free passes available to exhibitors.
- All hanging exhibits in Craft Classes must be suitably framed and fitted with appropriate hanging wire; otherwise, they will not be displayed.
- All exhibits for sale must be clearly marked with price. Exhibits not for sale must be marked "NFS".
- Commission of 20% will apply to all works sold and must be included in the sale price. Please liaise with Chief Steward.
- Sold exhibits must not be removed until **Saturday 18th July 2026**.
- Please ensure you are aware of your class number. This is the number on the far-left hand side of the class description in Schedule
- Translation card (if necessary) attached to item on the right-hand corner at the front.

CRAFT

OPEN CRAFT

- Class 27001:** Thrift Article
Made from scrap material - any medium
- Class 27002:** Any Upcycled Article
Any medium - Paper, Metal, Wood, Fabric. Description to be included.
- Class 27003:** Woodburning
- Class 27004:** Novelty Article
- Class 27005:** 2 Coat Hangers
Any medium - 2 distinctive patterns.
- Class 27006:** Toy
Any medium - not knitted or crocheted.
- Class 27007:** Macrame
- Class 27008:** Beadwork - Jewellery
- Class 27009:** Beadwork - Any Other Article
- Class 27010:** Mosaic - 2 Dimensional
- Class 27011:** Mosaic - 3 Dimensional
- Class 27012:** Dressed Doll
- Class 27013:** Scrapbooking - Category 'Christmas'
Open Class - One page, in plastic sleeve.
- Class 27014:** Scrapbooking - Category 'Celebration' of Anything
Open Class - One page in plastic sleeve.
- Class 27015:** Scrapbooking - Category 'Heritage'
Open Class - One page in Plastic Sleeve
- Class 27016:** Paper Crafting Card
For any Occasion and Technique
- Class 27017:** Paper Crafting Technique
Handmade Books, Altered Books, Paper Tole, Paper Sculpture, etc.
- Class 27018:** Christmas Decoration - Any Article
- Class 27019:** Millinery
Any medium, any style.
- Class 27020:** Resin Work
- Class 27021:** Woodburning
- Class 27022:** Any Other Article Not Mentioned
- Class 27023:** Miniatures
Any Medium

OPEN COMBINATION CRAFT

- Class 27024:** Any Article
Open Class - Wood metal, wire, mixed media, crochet/knitting, sewing/dying - Be creative
- Class 27025:** Group Projects
5 people or more

ENHANCE A BAG

Entry Fee: FREE

Prize: 1st - \$8, 2nd - \$4

Class 27026: Enhance a Bag

Class 27027: Up-Cycled Bag

Participants are invited to take a plain, everyday bag - such as a tote bag, handbag, backpack, or similar - and transform it into a unique and visually striking piece.

Entries may be decorated using a range of materials, including embellishments, fabric additions, paint, or other creative elements. Competitors are encouraged to demonstrate originality and creativity in their designs.

Judging will be based on creativity, workmanship, and overall presentation.



CRAFT – CONTINUED

HAND DRAWN ART:

Created Using Repetitive Patterns (Tangles)

SPECIAL REGULATIONS:

1. Min Size: Greeting Card
2. Max Size: A4
3. No signatures on front of artwork

Class 27028: Abstract Repetitive Patterns (Tangles)
Viewed from any orientation. Black, white with grey shading palette only.

Class 27029: Traditional Art or Structured
Designed together with Repetitive Patterns (Tangles). Viewed from a specific orientation. Any colour palette.

CHAMPION OPEN CRAFT OF SHOW - \$20

Open to Classes 27001 - 27029

Prize: \$20 + Sash

FOLK ART:

All Folk Art exhibits must comply with the Conditions of Entry.

Class 27030: Folk Art - Junior
For children Under 15 Years. MUST have been completed in a classroom situation and must be the unaided work of the exhibitor.

Class 27031: Folk Art - Beginners
Less than 2 Years experience

Class 27032: Folk Art - Intermediate
Over 2 Years' experience

Class 27033: Folk Art - Open Traditional
Baroque, Bauernmalerei, Hinderloopen, Intarsia, Naïve, Rosemailing, Russian Floral.

Class 27034: Folk Art - Open Decorative
Floral and other themes, boats, fairies, lace, teddies, etc.

CHAMPION FOLK ART OF SHOW - \$20

Open to Classes 27030 - 27034

Prize: \$20 + Sash

JUNIOR CRAFT - 12 YEARS AND UNDER

Prize: 1st - \$5, 2nd - \$3, 3rd - \$2, Highly Commended Card.

Class 27035: Beadwork
Any Article

Class 27036: Novelty - Made from Paper Plate

Class 27037: Christmas Decoration
Hanging Christmas Tree Decoration or Christmas Table Decoration

Class 27038: French Knitting
Any Article

CRAFT – CONTINUED

- Class 27039:** Toy
Any Article
- Class 27040:** Paddle Pop Sticks
Any Article
- Class 27041:** Paper Mache
Any Article
- Class 27042:** Scrapbooking
Any Category, One Page, in Plastic Sleeve.
- Class 27043:** Loom Craft
- Class 27044:** Any Other Article Not Mentioned
- Class 27045:** Paper Crafting Card
Card for any Occasion and Technique.
- Class 27046:** Any Machine Sewn Article or Clothing
- Class 27047:** Two Coat Hangers
Any Medium

CHAMPION JUNIOR CRAFT 12 YEARS AND UNDER OF SHOW - \$10

Prize: \$10 + Sash

JUNIOR CRAFT - 13 YEARS TO UNDER 18 YEARS

Prize: 1st - \$5, 2nd - \$3, 3rd - \$2, Highly Commended Card.

- Class 27048:** Beadwork
Any Article
- Class 27049:** Novelty Made from Paper Plate
- Class 27050:** Christmas Decoration
Hanging Christmas Tree Decoration or Christmas Table Decoration.
- Class 27051:** French Knitting
Any Article
- Class 27052:** Toy
Any Article
- Class 27053:** Paddle Pop Sticks
Any Article
- Class 27054:** Paper Mache
Any Article
- Class 27055:** Scrapbooking
Junior Class - Any Category, One Page, in plastic sleeve.
- Class 27056:** Loom Craft
- Class 27057:** Any Other Article Not Mentioned
- Class 27058:** Paper Crafting Card
For any Occasion and Technique
- Class 27059:** Any Machine Sewn Article or Clothing
- Class 27060:** Two Coat Hangers
Any Medium

CHAMPION JUNIOR CRAFT 13 YEARS TO UNDER 18 YEARS OF SHOW - \$10

Prize: \$10 + Sash



NEEDLEWORK

Exhibits must not be washed but should be well pressed. Cleanliness is essential for hand work. All exhibits must have been executed/completed within the last twelve (12) months prior to the 2026 Cairns Show.

Entry Fee: FREE

Prize: 1st - \$8 + Card, 2nd - \$4 + Card, 3rd - Card, Highly Commended Card - *unless otherwise stated*

OPEN CROCHET

Class 27061: Infant's Bonnet or Booties

Class 27062: Baby's Outfit

No less than 4 pieces (a pair of booties is classed as 1 piece).

Class 27063: Doyley

Up to 21 cm

Class 27064: Table Centre

Over 21cm

Class 27065: Runner or Tray Cloth

Class 27066: Handkerchief

Class 27067: Lady's Stole or Shawl

Any Medium

Class 27068: Tea Cosy

Any Medium

Class 27069: Cushion

Any Medium

Class 27070: Toy

Any Medium

Class 27071: Bedspread or Knee Rug

Any Medium

Class 27072: Fridge Towel

Class 27073: Any Other Article Not Specified

CHAMPION CROCHET OF SHOW - \$20

Prize: \$20 + Sash

Sponsored by ORN Alterations



OPEN HAND KNITTING

Class 27074: Infant's Bonnet or Booties

Class 27075: Baby's Outfit

No less than 4 pieces (a pair of booties is classed as 1 piece).

Class 27076: Adults Pullover, Vest, Cardigan or Garment

Class 27077: Toy

Class 27078: Tea Cosy

Class 27079: Any Other Knitted Article Not Specified

CHAMPION OPEN HAND KNITTING OF SHOW - \$20

Prize: \$20 + Sash

NEEDLEWORK – CONTINUED

MACHINE KNITTING

Class 27080: Machine Knitting Novice

CHAMPION MACHINE KNITTING NOVICE - LESS THAN TWELVE MONTHS EXPERIENCE - \$20

Prize: \$20 + Sash

Class 27081 Machine Knitting Open

CHAMPION MACHINE KNITTING OPEN - \$20

Prize: \$20 + Sash

OPEN HAND EMBROIDERY

Class 27082: Smocked

Any Article. Smocking - 90% = Judging, 10% = Finishing of Article

Class 27083: Applique Work

Class 27084: Table Centre

Class 27085: Cross Stitch Picture Framed

Class 27086: Cross Stitch and Embellishments

Class 27087: Cross Stitch – Any Other Article Not Mentioned

Class 27088: Needlework Picture Including Tapestry

Must be Framed

Class 27089: Tapestry Longstitch Picture

Must be Framed

Class 27090: Hardanger

Any Article

Class 27091: Runner or Tray Cloth

Class 27092: Doyleys

3 Distinctive Patterns

Class 27093: Hand Embroidery Traditional

Class 27094: Hand Embroidery Contemporary

Class 27095: Fabric Hand Stitched Book

Journal may include some free Machine Embroidery. Any Article.

Class 27096: Pin Cushion

Any Medium

CHAMPION OPEN HAND EMBROIDERY OF SHOW - \$20

Prize: \$20 + Sash

Sponsored by ORN Alterations



BOBBIN LACE

Entry Fee: FREE

Prize Money: 1st - \$50, 2nd - \$25, 3rd - \$10

Class 27097 Bobbin Lace

Type of lace and designers name (or own design) to accompany exhibit.

CHAMPION BOBBIN LACE OF SHOW - \$20

Prize: \$20 + Sash

NEEDLEWORK – CONTINUED

OPEN MACHINE SEWING

Any item professionally quilted must be entered into the relevant section. Example: Patchwork, Applique etc. not into quilting.

- Class 27098:** Embroidery
Any Medium
- Class 27099:** Applique Work
- Class 27100:** Quilting
Any Article
- Class 27101:** Art Quilt
- Class 27102:** Child's Garment
- Class 27103:** Evening Wear
- Class 27104:** Garment
- Class 27105:** Decorated Hand Towel and Washer Set
- Class 27106:** Apron
- Class 27107:** Patchwork
- Class 27108:** Bag
Any Medium
- Class 27109:** Cushion
Any Medium
- Class 27110:** Machine Sewing
Minimum of 3 Machine Sewing techniques - Any Article.
- For example:** *Patchwork, Quilting, Applique or Machine embroidery. Please provide description of how item was made and what techniques were used. It can include dying and hand embroidery but must have a minimum of 3 Machine Sewing techniques.*
- Class 27111:** Any Other Machine-Made Article Not Specified
- For example:** *printed panel with minimum outline quilting*

NOVICE SEWING

Prize: One year membership to the Australian Sewing Guild
Sponsored by the Australian Sewing Guild



- Class 27112:** Any Garment
Sewing of a garment (non-stretch) woven fabric, suitable for adults or teenagers.

CHAMPION MACHINE SEWING OF SHOW - \$20

Prize: \$20 + Sash + Sewing Machine
Sponsored by Dreaming Sewing Supplies



NEEDLEWORK – CONTINUED

70 YEARS AND OVER

- Class 27113:** Crochet
Any Article
- Class 27114:** Knitting
Any Article
- Class 27115:** Embroidery Work
Any Article
- Class 27116:** Novelty
Any Article, including Fabric Books/Journals.
- Class 27117:** Any Other Article Not Mentioned
- Class 27118:** Free Motion Embroidery Work

CHAMPION 70 YEARS AND OVER - \$20

Prize: \$20 + Sash

80 YEARS AND OVER

- Class 27119:** Any Article

CHAMPION 80 YEARS AND OVER - \$20

Prize: \$20 + Sash

JUNIOR - 12 YEARS OF AGE AND UNDER

State Age on Entry Form.

Prize: 1st - \$5 + Sash, 2nd - \$3, 3rd - \$2, Highly Commended Card

- Class 27120:** Crochet
Any Article
- Class 27121:** Knitting
Any Article
- Class 27122:** Embroidery
Any Article
- Class 27123:** Novelty Garment
Machine Sewing
- Class 27124:** Patchwork Bag
- Class 27125:** Cushion
Machine Sewing
- Class 27126:** Toy
Any Medium
- Class 27127:** Dressed Doll
- Class 27128:** Two Coat Hangers
Any Medium
- Class 27129:** Pin Cushion
Any Medium
- Class 27130:** Any Article Not Specified

NEEDLEWORK – CONTINUED

JUNIOR - 13 YEARS TO UNDER 18 YEARS OF AGE

State Age on Entry Form

Prize: 1st - \$5 + Sash, 2nd - \$3, 3rd - \$2, Highly Commended Card

- Class 27131:** Crochet
Any Article
- Class 27132:** Knitting
Any Article
- Class 27133:** Embroidery Work
Any Article
- Class 27134:** Garment
Machine Sewing
- Class 27135:** Nightwear
Machine Sewing
- Class 27136:** Tea Cosy
Any Medium
- Class 27137:** Table Centre
Any Medium
- Class 27138:** Toy
Any Medium
- Class 27139:** Two Coat Hangers
Any Medium
- Class 27140:** Any Article Not Specified
- Class 27141:** Pin Cushion
Any Medium

CHAMPION JUNIOR OF SHOW - \$10

Prize: \$10 + Sash

SPECIAL NEEDS 12 YEARS AND UNDER

State Age on Entry Form

Prize: 1st - \$5 + Sash, 2nd - \$3, 3rd - \$2, Highly Commended Card

- Class 27142:** Crochet
Any Article
- Class 27143:** Knitting
Any Article
- Class 27144:** Embroidery Work
Any Article
- Class 27145:** Any Machine-Made Article
- Class 27146:** Any Craft Item
- Class 27147:** Any Other Painted Article
- Class 27148:** Any Article Not Specified
- Class 27149;** Pin Cushion
Any Medium

CHAMPION SPECIAL NEEDS 12 YEARS AND UNDER - \$10

Prize: \$10 + Sash

NEEDLEWORK – CONTINUED

SPECIAL NEEDS 13 YEARS TO UNDER 18 YEARS

State Age on Entry Form

Prize: 1st - \$5 + Sash, 2nd - \$3, 3rd - \$2, Highly Commended Card

- Class 27150:** Crochet
Any Article
- Class 27151:** Knitting
Any Article
- Class 27152:** Embroidery Work
Any Article
- Class 27153:** Any Machine-Made Article
- Class 27154:** Any Craft Item
- Class 27155:** Any Other Painted Article
- Class 27156:** Any Article Not Specified
- Class 27157:** Pin Cushion
Any Medium

CHAMPION SPECIAL NEEDS 13 YEARS TO UNDER 18 YEARS - \$10

Prize: \$10 + Sash

SPECIAL NEEDS - OPEN

State Age on Entry Form

Prize: 1st - \$5 + Sash, 2nd - \$3, 3rd - \$2, Highly Commended Card

- Class 27158:** Crochet
Any Article
- Class 27159:** Knitting
Any Article
- Class 27160:** Embroidery Work
Any Article
- Class 27161:** Any Machine-Made Article
- Class 27162:** Any Craft Item
- Class 27163:** Any Other Painted Article
- Class 27164:** Any Article Not Specified
- Class 27165:** Pin Cushion
Any Medium

CHAMPION SPECIAL NEEDS - OPEN - \$20

Prize: \$20 + Sash

GRAND CHAMPION NEEDLEWORK ARTICLE OF SHOW - \$20

Prize: \$20 + Sash

Sponsored by ORN Alterations

GRAND CHAMPION OF HALL - \$20

Prize: \$20 + Sash

Sponsored by ORN Alterations



LAPIDARY

KEY INFORMATION

Entry Fee: FREE – *limit of 2 entries per person, per class*

Prize: 1st - \$8 + Card, 2nd - \$4 + Card, 3rd - Card, Highly Commended Card

Delivery of Exhibits: All entries must be delivered by 10am Monday **1st June 2026**.

- Members of the Cairns Mineral & Lapidary Club must deliver their entries to the Club directly.
- Members of the Public must deliver their entries to the Cairns Show Office.
- All entries must be accompanied by the General Entry Form, or a copy of the Showday Online entries.

Judging: 12pm **Tuesday 14th July**. Judge is an accredited Judge for QLD Lapidary & Allied Craft Clubs Association (QLACCA).

Collection of Exhibits: TBC.

CONDITIONS OF ENTRY

- The competition is classed as a level two competition. This competition shall be run in accordance with the AFLACA Competition and Judging Manual Issue No. 8, April 2015.
- All possible care will be taken with entries, but the committee will not be held responsible for any loss or damage during display, storage, or transport. Insurance is the responsibility of the competitor.
- All entries are to be the applicant's own work. No entry must have won at the same level, group, and division.

NOVICE SECTION

Class 27166: N.1A Standard Cabochon
Minimum Size 29mm on Longest Axis. Any material - craftsmanship.

Class 27167: N.16 Gem Tree

Class 27168: N.8A Faceted Standard Round Brilliant with Continuous Girdle
Minimum Size 8mm - Quartz

Class 27169: N.18D Hand Fabricated Jewellery with Commercial Lapidary Item/s
Set by Entrant - Any material.

Class 27170: N.18E Wire Wrapped Jewellery with Lapidary Item Cut and Set by Entrant

Class 27171: N.20A Cast Jewellery Not Intended to Include Lapidary

OPEN SECTION

Class 27172: O.1B Fancy Cabochon
Any material - craftsmanship.

Class 27173: O.9A Faceted Standard Oblong Step cut with Cut Corners
Quartz.

Class 27174: O.18A Hand Fabricated Jewellery without Lapidary

Class 27175: O.18E Wire Wrapped Jewellery with Lapidary Item/s Cut and Set by Entrant
Any material.

STANDARD OBLONG STEP CUT WITH CUT CORNERS

Section O.9A **Quartz** Facets 53: Meets 44 (Crown – 24, Pavilion – 20)
 NOTE: Stone L/W ratio must generate an obvious 'keel'
 Angles for R.I. = 1.540
 45 + 8 girdles = 53 facets
 2-fold, mirror-image symmetry
 96 index
 L/W & T/W = refer to step G2 U/W = 0.554
 P/W = 0.656 C/W = 0.240
 Vol./W³ = refer to step G2

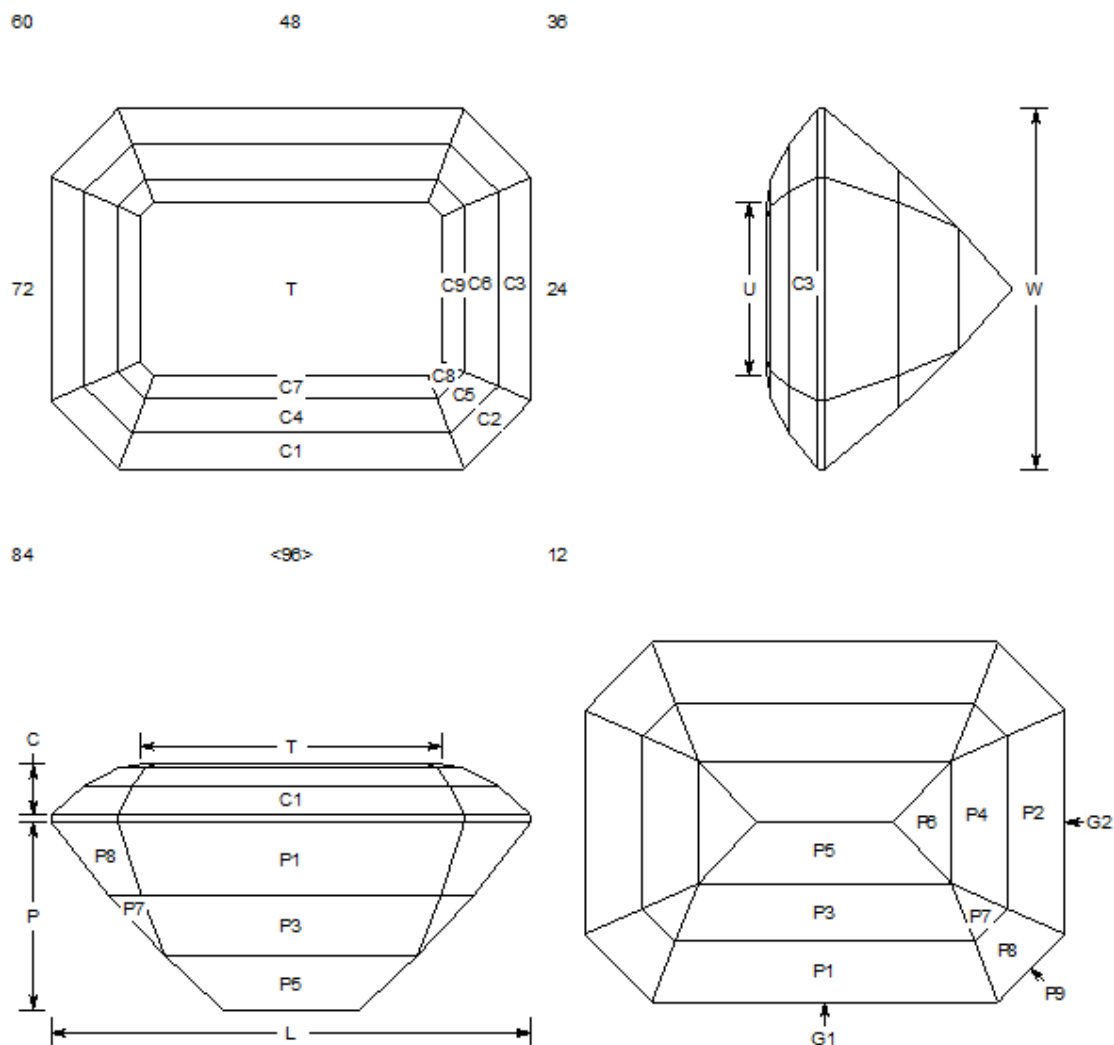

PAVILION				CROWN			
G1	90.00°	96-48	Set width	C1	55.00°	96-48	Set girdle thickness
G2	90.00°	24-72	Set length, see NOTE	C2	55.00°	12-36-60-84	Level girdle
P1	63.00°	96-48	Form girdle	C3	55.00°	24-72	Level girdle
P2	63.00°	24-72	Level girdle	C4	42.00°	96-48	Judge height by eye
P3	53.00°	96-48	Judge depth by eye	C5	42.00°	12-36-60-84	Meet C1-C2-C4
P4	53.00°	24-72	Meet P1-P2-P3	C6	42.00°	24-72	Meet C2-C3-C5
P5	43.00°	96-48	Judge depth by eye, form keel	C7	26.00°	96-48	Judge height by eye
P6	43.00°	24-72	Meet P3-P4-P5	C8	26.00°	12-36-60-84	Meet C4-C5-C7
P7	53.00°	12-36-60-84	Meet P3-P4-P5-P6	C9	26.00°	24-72	Meet C5-C6-C8
P8	63.00°	12-36-60-84	Meet P1-P3-P7	T	0.00°	Table	Judge height by eye
P9	90.00°	12-36-60-84	Level girdle				

STANDARD ROUND BRILLIANT WITH CONTINUOUS GIRDLE

Section N.8A

Quartz

Facets 58: Meets 41 (Crown – 24, Pavilion – 17)

Angles for R.I. = 1.540

57 + 1 rolled girdle = 58 facets

8-fold, mirror-image symmetry

96 index

L/W = 1.000 T/W = 0.556 U/W = 0.556

P/W = 0.450 C/W = 0.139

Vol./W³ = 0.198

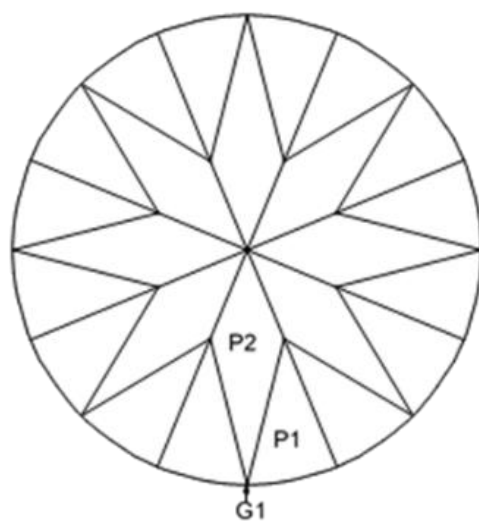
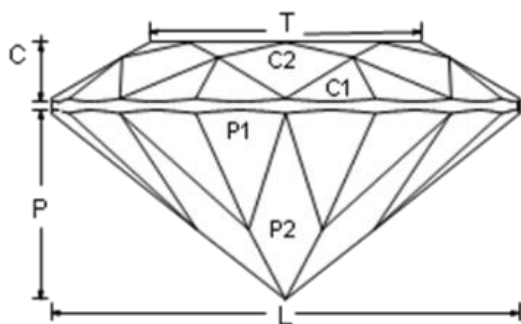
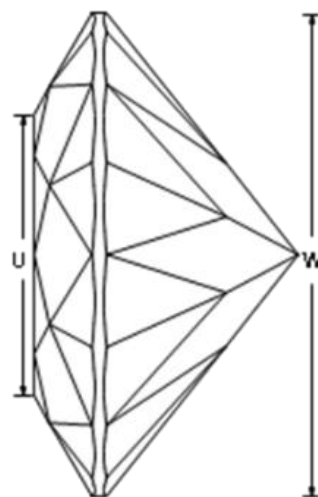
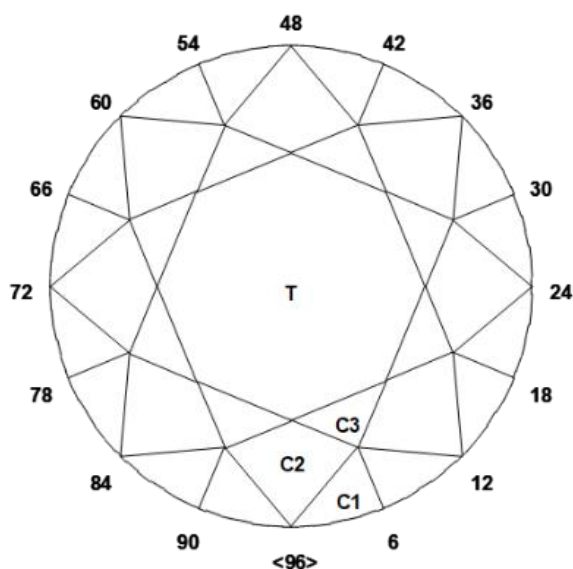

PAVILION

CROWN

03-09-15-21-27-33-39-45-51-57-63-69-75-81-87-93	Create TCP	C1	42.00 ⁰	03-09-15-21-27-33-39-45-51-57-63-69-75-81-87-93	Set girdle thickness
Girdle	Cut to size, rolled girdle	C2	35.00 ⁰	96-12-24-36-48-60-72-84	Meet C1, G
96-12-24-36-48-60-72-84	Meet P1, G, form PCP	C3	20.00 ⁰	06-18-30-42-54-66-78-90	Meet C1, C2
		T	0.00 ⁰	Table	Meet C3, C2, C3

ARTS & CRAFTS PAVILION

LEGO CHALLENGE

LEGO BUILDING - MAKE YOUR OWN DESIGN

PRIZES TO BE WON!

JUNIOR
1st - \$8
2nd - \$4

OPEN
1st - \$20
2nd - \$10

JUNIOR

CLASS 27176 - UNDER 12 YEARS

CLASS 27177 - 13 TO UNDER 18 YEARS

OPEN

CLASS 27178 - 18 YEARS & OVER

SPECIAL NEEDS

CLASS 217179 - UNDER 12 YEARS

CLASS 27180 - 13 TO UNDER 18 YEARS

CLASS 27181 - 18 YEARS & UNDER

MECHANICAL

CLASS 27182 - UNDER 12 YEARS

CLASS 27183 - 13 TO UNDER 18 YEARS

CLASS 27184 - 18 YEARS & OVER

CLASS 27185 - SPECIAL NEEDS - UNDER 12 YEARS

CLASS 27186 - SPECIAL NEEDS - 13 TO UNDER 18 YEARS

CLASS 27187 - SPECIAL NEEDS - 18 YEARS & OVER



**CAIRNS
SHOW**



**15TH - 17TH
JULY 2026**

**SECTION 28
HOME
ECONOMICS**

SECTION 28 HOME ECONOMICS

OFFICIALS

Chief Steward: Ms. Carol Coates

KEY INFORMATION

Entry Fee: \$FREE

Prize: *As Stated*

Entries Close:

- Cookery & Sweets: 4pm **Tuesday 23 June.**
- Jams & Preserves: 4pm **Tuesday 23 June.**

Delivery of Exhibits:

All exhibits to be delivered and collected from Main Arena (Centre Ring) side of Arts and Crafts Hall under the De Jarlais Function Centre.

- Cookery & Sweets: 7am-11am **Tuesday 14th July.**
- Jams & Preserves: 9am-4pm **Thursday 9th or Friday 10th July**

Judging:

- Cookery & Sweets: 1pm **Tuesday 14th July.**
- Jams & Preserves: 9am **Saturday 11th July.**

Collection of Exhibits: NOT BEFORE 10am-2pm Saturday 18th July.

SPONSORS

The Cairns Show Association wishes to record its sincere appreciation to the following Sponsors who have contributed to this area.

Cairns Agricultural, Pastoral and Mining Association, VG Bakery and Showbag Warehouse

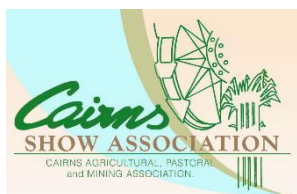

VG BAKERY

VG Bakery is a community-focused, not-for-profit initiative with a simple goal: to make a meaningful difference through every item we sell. 100% of our profits go directly towards supporting those in need, particularly individuals and families who may not qualify for other forms of assistance.

Recently, following the tragic e-bike accident involving two teenagers, VG Bakery has contributed funeral support for the affected families - just one example of how the bakery gives back to the community. Through kindness, connection, and a love of baking, VG Bakery aims to turn everyday purchases into real support where it's needed most.

SECTION 28 HOME ECONOMICS

HOW TO ENTER

1. Complete an Entry online or in person at the Cairns Show Office, or post via PO Box 811 Bungalow, QLD 4870.
2. Pay for Entry Fees online, by direct deposit, or in person at the Cairns Show Office (cash accepted).
3. Entries must be delivered to the designated part of the Showgrounds by the due date time and date shown.

AFTER THE SHOW

- Exhibits NOT collected by **Friday 21 August 2026** will become Property of the Cairns Show Association.
- Prize Money can be collected between 9am and 4pm Monday to Friday **1st August to 28th August** from the Show Office if your total prize money is less than \$50.
- Proof of identity is required to collect Prize Money. If you are collecting prize money on behalf of someone else, a letter of authorisation from that person will be required.
- All Prize Money less than \$50 not collected by **28th August, 4pm 2026** will be returned to the Cairns Show Association Funds.
- Prize money of \$50 and over will be deposited to the entrant's nominated bank account **after 28th August**.
- Results will be available from the [Cairns Show website](#) AFTER the conclusion of the Show.

SPECIAL REGULATIONS

- Refer General Conditions of Entry & Competition in front of Schedule.
- All exhibits must be the original and unaided work of the exhibitor. Factory made exhibits are not allowed in this Section.
- No exhibit can be entered into more than one class.
- Exhibitors should check exhibits for freshness - spoiled exhibits are automatically disqualified.
- All cakes will be cut during the judging process.
- All exhibits are to be on WHITE PAPER plates only, relevant to cake/slice size. Name and address to be written or attached on the back of the plate
- Exhibitors' name, address and/or phone number must be written on the back of the Class Card. Class Cards will be issued prior to the event for pre-entered exhibits, or on arrival for late entries.
- Class Card must be affixed to the front of the paper plate. Please ensure your exhibit card is readable and visible when attached to your exhibit.
- No person other than Judges and Stewards to be present while judging is in progress. Art & Crafts Pavilion will be locked during judging. The Judge reserves the right to alter the Class of an exhibit.
- Out of town exhibitors may collect exhibits following the fireworks for 30 minutes on **Friday night 17th July 2026**. Prior arrangements to be made with Chief Steward.
- Exhibits may be collected from Ring Side of Arts and Crafts Hall 10am to 2pm, **Saturday 18th July 2026**. No responsibility will be taken for exhibits left in the Arts & Crafts Pavilion after this time. All food will be disposed of.
- No free passes are available to exhibitors.

HOME ECONOMICS TIPS

Anzac Biscuits:	The biscuit must be crisp and should snap in half cleanly. Biscuits must be even thickness.
Banana Cake:	The cake should not crumble when cut and there should be no holes There will be specks of dark brown seeds showing through the cake. Colour inside should be light brown, free from soda specks. The texture should be fine, soft, even and moist.
Boiled Fruit Cake:	Fruit distributed evenly. Fruit should have a glossy look. Top should be nice and smooth and shiny and slightly domed.
Carrot Cake:	Golden to dark brown in colour. There will be specks of carrot and spice showing and these should be evenly distributed. The cake should not be crumbly.
Chocolate Cake:	Rich chocolate colour and flavour. It should cut evenly without crumbs and no holes. Textures should be fine, moist and even with no holes.
Chocolate Slice:	Uniform size and shape. The slices should have a neat unhandled look and be sharply cut with no ragged edges or crumbs.
Muffins:	Firm side and rounded top; uniform size and shape; no loose crumbs. The grain is not fine but should be uniform and moist.
Orange Cake:	Smooth sides, slightly rounded top. It should cut easily without crumbs; it should be fine and moist and without crumbs. Flavour and aroma of orange.
Patty Cakes:	The cakes should rise to the top of tin or patty paper and be nicely rounded. There should be no overhand from overfilling or flattening from too soft a mixture. When cut, the texture should be fine and moist, even and light and feel delicate in the hand.
Pikelets:	As round a shape as possible with uniform size and thickness. No sign of overcooked edges or grease. There should be no burst air bubbles showing. It should be well risen, not too thin or heavy.
Pumpkin Fruit Cake:	The top should have fine, even yellow golden skin that continues down the side. The top should be slightly domed. The colour inside should be golden.
Pumpkin Scones:	No pieces of pumpkin show when opened.
Scones:	Light and fine in texture - should flake when thumb is rolled across lightly. Size should be about 5cm. Scones should not touch and no flour on outside. Nicely browned on top and bottom.
Shortbread:	To be a delicate straw colour. Usually round with pinched edges, neatly pricked with a fork and marked into 6-8 triangles. It should snap nicely.
Sponge:	A good sponge is light and moist, but not soggy. Delicately and evenly browned with no overhanging or sugar spots. Both layers must be even. The texture should be light and soft and should spring back when touched.
Coconut Ice:	Firm, not hard, able to be cut. White and pink together.
Fudge:	Not sugary. Smooth texture on tongue.
Marshmallow:	It should spring back when pressed. Not bubbly, soft or sticky. Should be firm and break when twisted twice.
Toffee:	No bubbles - clear and the colour of straw. Not sticky. It should crack when hit with the handle of a knife.

HOME ECONOMICS TIPS

1. Always use fresh ingredients of good quality
2. Ingredients are best used at room temperature.
3. Butter and sugar should be well creamed, as a mottled top can result if not creamed enough.
4. Fruit should be of a uniform size in fruit cakes.
5. Spoon of anything is a level spoon.
6. 50 - 55-gram egg is best unless otherwise stated.
7. Avoid overmixing when using the “all-in-one” method, as this can make the cake tough.
8. Too much flour or too hot an oven could cause cake to crack.
9. Fan forced ovens should be 20° cooler than conventional ovens.
10. Use best quality cocoa for chocolate cakes and make sure it is sifted well to eliminate dark specks in cake.
11. Cavendish bananas are best for Banana Cakes
12. Make sure pumpkin is well mashed for Pumpkin Fruit Cakes so pumpkins specks do not show.
13. Paper should be smooth in tins to avoid marks on cakes
14. Put a tea-towel on the cooler before turning out cake to avoid marks on cake.
15. Do not have icing too thick and ice on top unless other stated, no decorations in centre of cakes, as it will drag when cake is cut, and do not test centres as this leaves a hole when cut.
16. Fruit for Jam should be fresh and free of bruising or blemishes, do not add sugar to fruit until fruit is soft, unless recipe states otherwise, as fruit will not soften after sugar is added. Test for marmalade by pressing fruit between thumb and finger for softness.
17. Jelly should be sparkling and transparent with a fruit flavour.
18. Do not overboil as this can result in dark jams or marmalade.
19. To seal lid of jams, etc., invert jar on lid for two minutes as soon as it is filled. This also takes air bubbles out of jellies.
20. Pickled onions - choose small white onions, uniform in size, shape and age. Strain spiced vinegar before pouring so that it is free from specks. Cover onions completely with vinegar.
21. Pay special attention to the bottle’s size and shape.
22. Read your brochure/schedule.

CAIRNS SHOW  **15TH - 17TH JULY 2026**

TIPS FOR MAKING JAMS & PRESERVES

1. Use heavy based pot - the combination of heat and sugar is easy to burn
2. Don't double your recipe - double or triple batches at the one time will require longer cooking, therefore making your fruit overcook and break up.
3. Cook on a dry day - the jam will absorb moisture from the air, making it less likely to set.
4. Freeze a couple of saucers - use to test the jam to see if it has set.
5. The proportion of sugar in jam is 340 grams sugar to 1 kilograms fruit.
6. To sterilise jars, wash in warm soapy water, rinse, then place in a moderate oven for 20 minutes to sterilise. While hot, add hot preserve/jam, clean around top, screw on lid and seal properly to prevent mould or fermentation. Lid should suck in and pop as the contents cools down.

COOKERY

OPEN

Cake entries may be submitted as either a full cake or a half cake for judging and display purposes. Please note that any remaining portion of the cake should not be brought in separately, as it cannot be entered again in the same or any other class.

Prize: 1st - \$8, 2nd - \$4, 3rd - Card

- Class 28001:** Sponge Cake
Optional - Jam filled.
- Class 28002:** Any Bar Cake
- Class 28003:** Banana Cake
Iced
- Class 28004:** Boiled Fruit Cake
Approx. 20cm Tin
- Class 28005:** Dark Rich Fruit Cake
- Class 28006:** Any Other Fruit Cake
- Class 28007:** Packet Cake
Iced and Decorated - Label Included
- Class 28008:** Any Gluten Free Cake
Recipe included.
- Class 28009:** Any Vegan Cake
Recipe Included.
- Class 28010:** Infused Cake
Non Cannibas, recipe included, e.g. Earl Grey infused cake with vanilla butter cream.
- Class 28011:** Any Other Cake Not Mentioned
Must be Named.
- Class 28012:** Boiled Plum Pudding
Boiled in Cloth
- Class 28013:** Steamed Plum Pudding
Steamed in Basin
- Class 28014:** Microwaved Plum Pudding
- Class 28015:** Hot Cross Bun
- Class 28016:** Plain Scones
Plate of 6
- Class 28017:** Pumpkin Scones
Plate of 6
- Class 28018:** Traditional Damper
Plain, Sweet or Savoury, Flat or Domed
- Class 28019:** Slices
Plate of 6 (one mixture).
- Class 28020:** Anzac Biscuits
Plate of 6
- Class 28021:** Biscuits
Plate of 6 - Any Variety
- Class 28022:** Decorated Biscuits
- Class 28023:** Shortbread
Plate of 6
- Class 28024:** Patty Cakes
Decorated Plate of 6

OPTIONAL RECIPE

CAIRNS SHOW  **15TH - 17TH JULY 2026**

SPONGE CAKE RECIPE

INGREDIENTS

½ cup + 1 ½ tbsp granulated sugar	1 tsp grated lemon zest or vanilla extract
4 extra-large eggs	1 cup cake flour or plain flour
A pinch of salt	

METHOD

1. Pre-heat oven to 170°.
2. Butter and flour (or spray with baking spray) a 20cm pan.
3. In the bowl, beat the eggs, sugar, salt, and lemon zest until very fluffy and pale yellow.
4. Sift the flour on top of the egg mixture, one-third at a time, and fold it gently with a wooden spoon or spatula just until incorporated.
5. Pour the batter into the prepared pan. Do not smooth the top or bang the pan on the counter.
6. Bake for 40 minutes or until the top is golden.
7. Turn off the oven, but leave the cake inside for 5-10 minutes.
8. Remove the sponge cake from the oven, let it cool for 10 minutes, then loosen the edges and flip onto a wire rack to cool completely.

OPTIONAL RECIPE

CAIRNS SHOW  **15TH - 17TH JULY 2026**

SCONE RECIPE

INGREDIENTS

3 cups self-raising flour	1 to 1 ¼ cups milk
80g butter	Plain flour, for dusting

METHOD

1. Pre-heat oven to 200°.
2. Sift self-raising flour into a large bowl.
3. Using your fingertips, rub butter into self-raising flour until mixture resembles breadcrumbs.
4. Make a well in the centre. Add 1 cup of the milk. Mix with a flat-bladed knife until mixture forms a soft dough, adding more milk if required.
5. Turn onto a lightly floured surface. Knead gently until smooth.
6. Lightly dust a flat baking tray with plain flour.
7. Pat dough into a 2cm-thick round. Using a 5cm round cutter, cut out 12 rounds. Press dough together and cut out remaining 4 rounds.
8. Place scones onto prepared baking tray, 1cm apart. Sprinkle tops with plain flour. Bake for 12-15 minutes or until golden and well risen.
9. Transfer to wire rack.

COOKERY – CONTINUED

- Class 28025:** Cup Cakes
Decorated Plate of 6
- Class 28026:** Pikelets
Plate of 6
- Class 28027:** Muffins
Plate of 6 - Any Variety

CHAMPION OF OPEN COOKERY SECTION - \$55

Prize: \$55 + Sash

OFFICE / WORKPLACE CAKE CHALLENGE

Class 28028: Office / Workplace Cake Challenge

Compete with colleagues and other local businesses to determine who can produce the best cake.

This friendly competition is a great opportunity to build team spirit, engage with the wider business community, and enjoy some outstanding baked creations.

COOKERY – CONTINUED

JUNIOR - 12 YEARS & UNDER

Cake entries may be submitted as either a full cake or a half cake for judging and display purposes. Please note that any remaining portion of the cake should not be brought in separately, as it cannot be entered again in the same or any other class.

Prize: 1st - \$5, 2nd - \$3, 3rd - \$2

- Class 28029:** Hot Cross Bun
- Class 28030:** Plain Scones
Plate of 6
- Class 28031:** Pikelets
Plate of 6
- Class 28032:** Anzac Biscuits
Plate of 6
- Class 28033:** Biscuits
Plate of 6 - Any Variety
- Class 28034:** Orange Bar Cake
Iced
- Class 28035:** Chocolate Ring Cake
Iced
- Class 28036:** Boiled Fruit Cake
- Class 28037:** Packet Mix Cake
Iced & Decorated - Including Label
- Class 28038:** Cup Cakes
Decorated - Plate of 6

OPTIONAL RECIPE

CAIRNS SHOW  **15TH - 17TH JULY 2026**

ANZAC BISCUIT RECIPE

INGREDIENTS

1 cup plain flour	125g butter
1 cup rolled oats	1 tbsp golden syrup
1 cup desiccated coconut	1 tbsp hot water
1 cup brown sugar	1 tsp bicard soda

METHOD

1. Pre-heat the oven to 175°.
2. Combine the flour, oats, coconut and sugar in a large bowl. In a saucepan, melt the butter and then add the golden syrup. Bring it to the boil before removing it from the stove.
3. Mix the hot water and bicard soda and add it to the butter and syrup - it should froth up. Pour this into the dry ingredients and stir together. If the mixture is a little dry, add some water.
4. Take spoonfuls of the mixture, roll them into balls and place them on a greased baking tray, about 5cm apart. Use a fork to flatten them and then put them in the oven for 15 minutes or until they're golden brown.
5. Once they're removed from the oven, let the biscuits cool on the baking tray for about a minute, then move them to a wire rack to cool completely.

COOKERY – CONTINUED

- Class 28039:** Patty Cakes
Decorated - Plate of 6
- Class 28040:** Slices
Plate of 6
- Class 28041:** Arrowroot Biscuits
Iced and Decorated - Plate of 6
- Class 28042:** Muffins
Plate of 6 - Any Variety
- Class 28043:** Any Other Cake Not Mentioned
Must be Named

CHAMPION OF JUNIOR COOKERY 12 YEARS & UNDER - \$25

Prize: \$25 + Sash

JUNIOR - 13 YEARS TO UNDER 18 YEARS

Cake entries may be submitted as either a full cake or a half cake for judging and display purposes. Please note that any remaining portion of the cake should not be brought in separately, as it cannot be entered again in the same or any other class.

Prize: 1st - \$5, 2nd - \$3, 3rd - \$2

- Class 28044:** Sponge Cake
1 Layer
- Class 28045:** Hot Cross Bun
- Class 28046:** Plain Scones
Plate of 6
- Class 28047:** Pikelets
Plate of 6
- Class 28048:** Anzac Biscuits
Plate of 6
- Class 28049:** Biscuits
Plate of 6 - Any Variety
- Class 28050:** Decorated Biscuits
- Class 28051:** Orange Bar Cake
Iced
- Class 28052:** Chocolate Ring Cake
Iced
- Class 28053:** Boiled Fruit Cake
- Class 28054:** Packet Cake Mix
Iced & Decorated - Including Label
- Class 28055:** Cup Cakes
Decorated - Plate of 6
- Class 28056:** Patty Cakes
Decorated - Plate of 6
- Class 28057:** Slices
Plate of 6 - Any Variety
- Class 28058:** Muffins
Plate of 6 - Any Variety
- Class 28059:** Any Other Cake Not Mentioned
Must Be Named

OPTIONAL RECIPE

CAIRNS SHOW  **15TH - 17TH JULY 2026**

MUFFIN RECIPE

INGREDIENTS

2 cups all-purpose flour	¾ cup milk
½ cup granulated sugar	½ cup butter
1 tsp baking powder	2 large eggs
½ tsp salt	2 tbsp coarse sugar

METHOD

1. Preheat the oven to 180°. Line a muffin pan with paper liners; set aside.
2. In a small bowl, whisk the flour, sugar, baking powder, and salt together.
3. In a medium bowl, whisk the milk, butter, and eggs together until well combined.
4. Add the flour mixture and stir with a silicone spatula just until combined.
5. Divide the batter evenly between the muffin cups and sprinkle the tops with coarse sugar if using.
6. Bake for 20-25 minutes, or until a toothpick inserted into the center comes out with only a few moist crumbs attached.
7. Transfer muffins to a wire rack to cool completely. Muffins are best the day they are made but they can be stored for later use.

COOKERY – CONTINUED

Class 28060: Child's Birthday Cake
Prize: 1st - \$10, 2nd - \$6, 3rd - \$4
Novelty - Decorated

CHAMPION OF JUNIOR COOKERY 13 YEARS TO UNDER 18 YEARS - \$25

Prize: \$25 + Sash

SPECIAL NEEDS – COOKERY

Prize: 1st - \$5, 2nd \$4, \$2

Cake entries may be submitted as either a full cake or a half cake for judging and display purposes. Please note that any remaining portion of the cake should not be brought in separately, as it cannot be entered again in the same or any other class.

12 YEARS & UNDER.

Class 28061: Any Cake
Must be named.
Class 28062: Decorated Cake
Any Cake
Class 28063: Any Slice or Biscuit
Plate of 6
Class 28064: Decorated Biscuit
Any Biscuit

CHAMPION SPECIAL NEEDS 12 YEARS AND UNDER - \$25

Prize: \$25 + Sash

13 YEARS & UNDER 18 YEARS

Class 28065: Any Cake
Must be named.
Class 28066: Decorated Cake
Any Cake
Class 28067: Any Slice or Biscuit
Plat of 6
Class 28068: Decorated Biscuit
Any Biscuit

CHAMPION SPECIAL NEEDS 13 YEARS AND UNDER 18 YEARS - \$25

Prize: \$25 + Sash

DECORATED EGGS**Entry Fee:** FREE**Prize:** 1st - \$8, 2nd - \$4

Participants are invited to create beautifully decorated eggs using natural and eco-friendly techniques. Eggs may be coloured or decorated using materials such as turmeric, red cabbage, onion skins, beetroot, coffee, or baking soda mixed with food colouring and water. For added effect, vinegar may be poured over the baking soda mixture to create unique textures and patterns.

Entries will be judged on presentation, creativity, and effective use of natural colouring techniques. All eggs must be clean and suitable for display.

Class 28069: Decorated Eggs
Plate of 3
Card with technic



SPARKLE STONES

Entry Fee: FREE

Prize: 1st - \$8, 2nd - \$4

Participants are invited to create colourful and creative sparkle rocks using simple, fun materials.

Sparkle rocks can be made using a mixture of 2 parts flour, 2 parts salt, and 1 part warm water to form a dough. Add your favourite food colouring shades and finish with sparkly glitter for extra shine. No oven is required - simply shape your creations and allow them to harden overnight.

Entries will be judged on presentation, creativity, and effective use of colour and sparkle. All entries must be dry, set, and suitable for display.

Class 28070: Sparkle Stones



SWEETS

OPEN

Prize: 1st - \$8, 2nd - \$4, 3rd - Card

- Class 28071:** Rum or Fruit Balls
Plate of 6
- Class 28072:** Coconut Ice
Plate of 6
- Class 28073:** Chocolate Fudge
Plate of 6
- Class 28074:** Marshmallow
Plain, Toasted or Fancy - Plate of 6
- Class 28075:** Jellies
Plate of 6
- Class 28076:** Plate of Any Other Homemade Sweets

JUNIOR - UNDER 18 YEARS

Prize: 1st - \$5, 2nd - \$3, 3rd - \$2

- Class 28077:** Fruit Balls
Plate of 6
- Class 28078:** Coconut Ice
Plate of 6
- Class 28079:** Chocolate Fudge
Plate of 6
- Class 28080:** Marshmallows
Plain, Toasted or Fancy - Plate of 6
- Class 28081:** Any Other Sweet Not Specified
Plate of 6

OVERALL CHAMPION OF JUNIOR SWEETS - \$25

Prize: \$25 + Sash

OPTIONAL RECIPE

CAIRNS SHOW  **15TH - 17TH JULY 2026**

MARSHMALLOW RECIPE

STAND MIXER REQUIRED

INGREDIENTS

1 cup water	A pinch of salt
60g powdered gelatin	Optional: Vanilla Bean
200g raw honey	

1. Use 125 ml water to bloom the gelatin.
2. In a small saucepan, combine honey, salt and the remaining 125 ml water. Heat over medium heat until smooth and slightly darker, or until it reaches 100°. Remove from heat and cool for 10 minutes.
3. Place the bloomed gelatin in a stand mixer and mix briefly on low speed to break it up. Slowly drizzle the honey mixture down the side of the bowl while mixing.
4. Increase to high speed and whip for 12-15 minutes until thick, fluffy and forming stiff peaks.
5. Pour into a lined dish and refrigerate for 1 hour until set.

JAMS & PRESERVES

Exhibits: All exhibits containing gelatine or artificial pectin will be disqualified.

Preserves: All preserve exhibits will only be accepted in jars ranging from approx. 120ml or 1/2 cup in size.

Jams/Sauces: All jam/sauce exhibits will only be accepted in screw top jars/bottles not necessarily vacola type jars) ranging from 120ml or 1/2 cup in approximate size and labelled.

No lid covers, including material covers.

OPEN

Prize: 1st - \$8, 2nd - \$4, 3rd - Card

- Class 28082:** Rosella Jam
1 Jar
- Class 28083:** Cumquat Jam
1 Jar
- Class 28084:** Jam - Any Variety from Dried Fruit
1 Jar
- Class 28085:** Jam - Any Other Variety
1 Jar
- Class 28086:** Orange Marmalade
1 Jar
- Class 28087:** Grapefruit Marmalade
1 Jar
- Class 28088:** Cumquat Marmalade
1 Jar
- Class 28089:** Marmalade - Any Other Variety
1 Jar
- Class 28090:** Jelly - Any Variety
1 Jar
- Class 28091:** Infused Jam, Jelly or Sauce
Non Cannibas - 1 Jar
- Class 28092:** Lemon Butter
1 Jar
- Class 28093:** Any Other Fruit Butter
1 Jar
- Class 28094:** Sauce - Savoury
Any Variety - 1 Bottle
- Class 28095:** Sauce - Dessert
Any Variety - 1 Bottle
- Class 28096:** Mayonnaise
Any Variety - 1 Jar or 1 Bottle
- Class 28097:** Relish
Any Variety - 1 Jar
- Class 28098:** Mango Chutney
1 Jar
- Class 28099:** Any Other Chutney
1 Jar

OPTIONAL RECIPE

CAIRNS SHOW  **15TH - 17TH JULY 2026**

TOMATO CHUTNEY RECIPE

INGREDIENTS

500gram tomatoes (chopped)	1 tsp ground coriander
250g red onions (chopped)	1 tsp salt
1 tbsp olive oil	75ml red wine vinegar 9or cider vinegar)
1 tsp ground cumin	120g brown sugar
1 red chilli	

METHOD

1. Heat oil in a pan and cook the onions, chilli, salt, and spices for 10 minutes until soft.
2. Add tomatoes, sugar, and vinegar. Stir well and bring to a boil.
3. Lower the heat and simmer for 40 minutes, stirring occasionally to prevent sticking.
4. The chutney is ready when a spoon dragged through it leaves a clear trail on the pan base.
5. Ladle into sterilized jars.

JAMS & PRESERVES – CONTINUED

- Class 28100:** Pickles - Mustard
Any Variety - 1 Jar
- Class 28101:** Pickles - Clear
Any Variety - 1 Jar
- Class 28102:** Fruit Cordial

OPEN - COLLECTIONS

Each Collection to be 4 Varieties.

Prize: 1st - \$10, 2nd - \$5, 3rd - Card

- Class 28103:** Collection of Jams or Marmalades
4 Varieties
- Class 28104:** Collection of Jellies
4 Varieties
- Class 28105:** Collection of Chutney & Relishes
4 Varieties
- Class 28106:** Collection of Preserved Fruit & Vegetables
4 Varieties

CHAMPION OPEN JAMS AND PRESERVES OF SHOW - \$20

Prize: \$20 + Sash

JUNIOR - UNDER 18 YEARS

100ml or 1/2 cup in size.

Prize: 1st - \$5, 2nd - \$3, 3rd - \$2

- Class 28107:** Jam
Any Variety - 1 Jar
- Class 28108:** Jelly
Any Variety - 1 Jar
- Class 28109:** Marmalade
Any Variety - 1 Jar
- Class 28110:** Butter
Any Variety - 1 Jar. Example: Lemon, Passionfruit,
- Class 28111:** Chutney
Any Variety - 1 Jar
- Class 28112:** Relish
Any Variety - 1 Jar
- Class 28113:** Pickles
Any Variety - 1 Jar

CHAMPION JUNIOR JAMS AND PRESERVES OF SHOW - \$10

Prize: \$10 + Sash

OPTIONAL RECIPE

CAIRNS SHOW  **15TH - 17TH JULY 2026**

PICKLE RECIPE

INGREDIENTS

1 medium cucumber	1 ½ cup white distilled vinegar
1 tsp coriander seed	vinegar
1 tsp mustard seed	1 tsp cane sugar
1 handful fresh dill sprigs	2 tsp salt

METHOD

1. Add cucumber slices to a large mason jar or glass container along with coriander seed, mustard seed, and dill. Set aside.
2. To a small saucepan add distilled white vinegar, sugar, and salt. Bring to a simmer over medium heat and stir to fully dissolve salt and sugar. Taste and adjust flavor as needed, adding more salt or sugar to taste.
3. Let the brine cool in the refrigerator for at least 30 minutes to 1 hour. Once cooled, pour the brine over the cucumbers until your glass container is full. Ensure the cucumbers are fully submerged. If needed, add more vinegar or a little water to cover.
4. Seal well and shake to combine. Then refrigerate for at least 1 hour. The flavors will deepen and intensify the longer it marinates. Best flavor is achieved after 24 hours.

SECTION 29 ICED CAKES

OFFICIALS

Chief Steward: Ms. Carol Coates

KEY INFORMATION

Entry Fee: *As Stated.*

Prize: *As Stated.*

Entries Close: 4pm **Friday 19th June**. Entries on the day of Delivery may be accepted.

Delivery of Exhibits: 7am-11am **Tuesday 14th July** WIN News Arts & Crafts Pavilion (underneath De Jarlais Function Centre).

Judging: 1pm **Tuesday 14th July**.

Collection of Exhibits: **NOT BEFORE** 10am-2pm **Saturday 18th July** - Main Arena (Centre Ring) side of Arts & Crafts Hall.

SPONSORS

The Cairns Show Association wishes to record its sincere appreciation to the following Sponsors who have contributed to this area.

Cairns Agricultural, Pastoral and Mining Association, Jackley's Bakehouse, and Mareeba Cake Decorators Association.

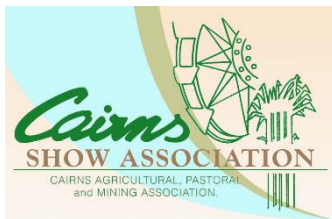

HOW TO ENTER

1. Complete an Entry online or in person at the Cairns Show Office, or post via PO Box 811 Bungalow, QLD 4870.
2. Entries will not be accepted over the phone or after the closing date.
3. Pay for Entry Fees online, by direct deposit, or in person at the Cairns Show Office (cash accepted).
4. Class cards can be picked up at the Cairns Showgrounds Office either before drop-off or at the time of delivery.
5. Entries must be delivered to the designated part of the Showgrounds by the due date time and date shown.

AFTER THE SHOW

- Exhibits NOT collected by **Friday 28th August 2026** will become Property of the Cairns Show Association.
- Prize Money can be collected between 9am and 4pm Monday to Friday, 1st August to 29th August 2026 from the Show Office if your total prize money is less than \$50.
- Proof of identity is required to collect Prize Money. If you are collecting prize money on behalf of someone else, a letter of authorisation from that person will be required.
- All Prize Money less than \$50 not collected by 29th August, 4pm 2026 will be returned to the Cairns Show Association Funds.
- Prize money of \$50 and over will be deposited to the entrant's nominated bank account after 28th August.
- Results will be available from the [Cairns Show website](#) AFTER the conclusion of the Show.

SPECIAL REGULATIONS

- Refer General Conditions of Entry & Competition in front of Schedule.
- Exhibits may be collected from 10am-2pm **Saturday 18th July**. No responsibility will be taken for exhibits left in the Arts & Craft Pavilion after this time. Out of Town exhibitors may collect exhibits following the Fireworks for 30 minutes on **Friday night 17th July 2026**. Prior arrangements must be made with Chief Steward.
- Exhibits for sale must be clearly marked and cannot be removed until **Saturday 18th July**.
- Commission of 20% will apply to all cakes sold and must be included in the sale price.
- No person other than Judges and Stewards to be present throughout duration of Judging. The Judge reserves the right to alter the Class of an exhibit.
- In the event of an exhibit in any one class not being worthy of a prize, no prize money, gift, etc., will be awarded
- No exhibit can be entered into more than one class.
- No free passes available to exhibitors.
- Entries that are not completed according to this schedule may be ineligible for a prize.
- All entries to be the bona fide handiwork of the exhibitor
- For All Classes the base, presentation board or drape must fit within the perimeter of a 45cm square. The base boards must be raised on cleats or runners. Pillars or other means of elevating cakes are permitted.
- Except where specifically otherwise mentioned, no non-sugar ornaments are allowed. No artificial paper, fabric flowers or leaves to be used and dried baby's breath is not permitted. However, minimal use of dried vegetable matter (e.g. polenta & semolina) may be used.
- Reasonable use of wire, tape, stamens, ribbons, cotton, tulle, gelatine, piping gel & posy pics are permitted. However, wires of any kind **MUST NOT** penetrate the surface of the exhibit, and no pins are allowed to hold ribbons, etc.
- Only minimal amounts of metallic paint and lustres will be allowed except for Open Contemporary Design.
- Information sheets for the Judges should be completed, if needed.
- To advise use of support.
- To clarify use of any item which may appear not to comply with schedule.
- For any explanation necessary to clarify exhibit.
- To clarify if your cake is a "Dummy".
- Name, Address & Phone Number on the back of Class Card.
- SECTIONS MARKED "JUNIOR" - Only children under 18 years are eligible to enter Junior Sections
- SECTIONS MARKED "NOVICE" - Novice Sections are only for exhibitors who have never won first prize in this class or any prize in the Open class and have not entered on more than four previous occasions.
- SECTIONS MARKED "INTERMEDIATE"- Intermediate Sections are only for exhibitors who have never won first prize in this class or any prize in the Open Class and have not entered on more than four previous occasions.
- SECTIONS MARKED "OPEN" - Open Sections can be entered by anyone irrespective of previous wins or age.
- Dummy Cakes may be used except in Class 29010 Novelty, where cake must be used to form shape.
- Translation card (if necessary) attached to item on the right-hand corner at the front.

POINTS OF INTEREST

1. **Bona fide Handiwork:** Must be handmade solely by the exhibitor.
2. **Sugar Paste:** Decorations made from sugar.
3. **Lace:** A piece of lace that is piped with royal icing.
4. **Extension work:** Piped with royal icing giving a delicate border finish to lower side sections of cake.
5. **Piping skills:** Royal icing that is piped directly onto the surface of the iced cake.
6. **Cleats or Runners:** Cleats must be adhered under boards sufficient to enable ease of handling.
7. **Pillars:** Supports tiered cakes - usually made in plastic, they come in different shapes and sizes.
8. **Wire:** Covered wire.
9. **Tape:** Florist tape to bind wire.
10. **Posy Pics:** Small plastic cone shaped holder.

JUNIOR

Entry Fee: \$1.10

Prize: 1st - \$20 + Trophy + Gift Voucher, 2nd - \$10, 3rd - \$8

11 YEARS & UNDER

Open to Children up to and including 11 Years.

Class 29001: Iced Cake
Any theme - to be judged on the originality of design and execution

Class 29002: Sugar Craft - No Cake Included
Floral arrangement and/or novelty. To be an imaginative creation, judged for ingenuity of design and execution, and arranged on a base board, no larger than 45cm x 45cm.

12 YEARS TO UNDER 18 YEARS

Open to Children 12 Years to Under 18 Years.

Class 29003: Iced Cake
Any theme - to be judged on originality of design and execution.

Class 29004: Sugar Craft - No Cake Included
Floral arrangement and/or novelty. To be an imaginative creation, judged for ingenuity of design and execution, and arranged on a base board, no larger than 45cm x 45cm.

NOVICE

Shop Owners, Tutors and Online Businesses can ONLY enter the Open Section.

Entry Fee: \$1.10

Prize: 1st - \$20 + Gift Voucher, 2nd - \$10 + Gift Voucher, 3rd - \$8

Class 29005: Special Occasion Cake
One- or two-tier Cake can be Wedding, Engagement, Birthday, Christening, Anniversary, Christmas, Easter Theme, etc. For exhibitors who have never won a first prize in this class or any prize in the Open Class and have not entered on more than four previous occasions.

INTERMEDIATE

Shop Owners, Tutors and Online Businesses can ONLY enter the Open Section.

Entry Fee: \$4.40

Prize: 1st - \$20 + Gift Voucher, 2nd - \$15 + Gift Voucher, 3rd - \$10

Class 29006: Special Occasion Cake

One- or two-tier cake can be Wedding, Engagement, Birthday, Christening, Anniversary, Christmas, Easter Theme, etc. Open to those who have not previously won a first prize in this Class or any prize in the Open Class and have not entered on more than four occasions.

OPEN

Entry Fee: \$4.40

Prize: As Stated.

Class 29007: Special Occasion Cake

Prize: 1st - \$35, 2nd - \$20, 3rd - \$10

One Cake only (excluding Wedding Cake).

Example: Engagement, Birthday, Christening, Anniversary, Christmas, Easter Theme, etc. Open to all exhibitors.

Class 29008: Wedding Cake

Prize: 1st - \$100, 2nd - \$40, 3rd - \$30

Two or three cakes to be tiered or otherwise presented on a common base board.

Class 29009: Contemporary Design

Prize: 1st - \$40, 2nd - \$20, 3rd - \$10

One or two cakes to be tiered or otherwise presented on a common base board, decorated using up to 5 cutters/tools. To be judged for ingenuity of design and execution of cutters. A minimum of three different types of cutter/tools must be used. Lustre, glitter, cachous, wires, rope, moulds, cutters, stencils, supports, pillars, perspex, colour, may be used but no artificial (e.g. silk flowers) or plastic (e.g. Bride and Groom) decorating items.

Class 29010: Novelty Cake

Prize: 1st - \$50, 2nd - \$20, 3rd - \$10

The exhibit may be sculptured from cake (dummy may be used).

Novelty is to be a themed cake not necessarily sculptured.

Judge must be given an information sheet on how the cake/s is/are constructed/content. Arranged on a base board no bigger than 45cm x 45cm.

Class 29011: Sugar Craft - No Cake Included

Prize: 1st - \$50, 2nd - \$20, 3rd - \$10

Floral arrangement and/or novelty.

To be an imaginative creation, judged for ingenuity of design and execution, and arranged on a base board, no bigger than 45cm x 45cm.

All exhibitors are eligible to enter this class.

BUTTERCREAM

Entry Fee: \$4.40

Prize: 1st - \$20, 2nd - \$15, 3rd - \$10.

Class 29012: Special Occasion Cake
*One- or two-tier Cake can be Wedding,
Engagement, Birthday, Christening, Anniversary, Christmas, Easter Theme etc.
Open to all exhibitors.*





**CAIRNS
SHOW**



**15TH - 17TH
JULY 2026**

**SECTION 31
WOODWORK**



SECTION 31 WOODWORK

OFFICIALS

Chief Steward: Ms. Carol Coates

Judge: Mr. Russel Geisel

KEY INFORMATION

Entry Fee: \$5 - *unless Otherwise Stated.*

Prize: 1st - \$20, 2nd - \$10, 3rd - \$5

Entries Close: 4pm **Friday 3rd July.**

Delivery of Exhibits: 9am-4pm **Thursday 9th July and Friday 10th July** - WIN News Arts & Crafts Pavilion (underneath De Jarlais Function Centre).

Judging: 9am **Saturday 11th July.**

Collection of Exhibits: **NOT BEFORE** 10am-2pm **Saturday 18th July** - Main Arena (Centre Ring) side of Arts & Crafts Hall.

SPONSORS

The Cairns Show Association wishes to record its sincere appreciation to the following Sponsors who have contributed to this area.

Cairns Agricultural, Pastoral and Mining Association.

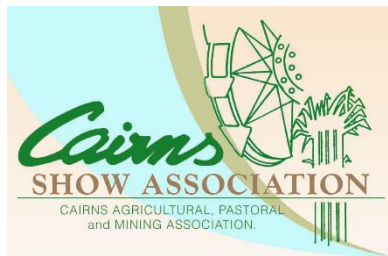

HOW TO ENTER

1. Complete an Entry online or in person at the Cairns Show Office, or post via PO Box 811 Bungalow, QLD 4870.
2. Entries will not be accepted over the phone. Entries may be accepted on the day of Delivery (subject to approval of the Chief Steward).
3. Pay for Entry Fees online, by direct deposit, or in person at the Cairns Show Office (cash accepted).
4. Entries must be delivered to the designated part of the Showgrounds by the due date and time shown.

AFTER THE SHOW

- Exhibits NOT collected by **28th August 2026** will become Property of the Cairns Show Association.
- Prize Money can be collected between 9am and 4pm Monday **to Friday 1st August to 28th August** from the Show Office if your total prize money is less than \$50.
- Proof of identity is required to collect Prize Money. If you are collecting prize money on behalf of someone else, a letter of authorisation from that person will be required.
- All Prize Money less than \$50 not collected by **28th August, 4pm 2026** will be returned to the Cairns Show Association Funds.
- Prize money of \$50 and over will be deposited to the entrant's nominated bank account after **28th August.**
- Results will be available from the [Cairns Show website](#) AFTER the conclusion of the Show.

SPECIAL REGULATIONS

- All exhibitors must enter woodwork into the appropriate class, e.g. Novice, Intermediate or Open.
- Novice Class is open to exhibitors who have never won a prize in the Woodwork Section in any previous competition and have not entered on more than two previous occasions and have never entered an exhibition in an Intermediate or Open Class.
- Open Class is open to all exhibitors.
- All exhibits for sale must be clearly marked with price. Exhibits not for sale must be marked "NFS". Commission of 20% will apply to all works sold and must be included in the sale price. Please liaise with Chief Steward.
- Exhibits to be collected from 10 am to 2pm **Saturday 18th July 2026**. No responsibility will be taken for exhibits left in the Woodwork Section after this time.
- Sold exhibits must not be removed until **Saturday 18th July 2026**.
- Entrants must use at least 90% timber in their creations, and all creations must be made in the last 12 months prior to the Cairns Show 2026.
- In the event of an exhibition in any one class not being worthy of a prize, no prize money will be awarded.
- No people other than Steward and Judge are to touch exhibits prior to Judging on Saturday **11th July 2026**. The Judge reserves the right to alter the Class of an exhibit.
- All exhibits are to be the original and unaided work of the exhibitor. Any exhibitor found to be aided by others in completing his/her exhibit will be disqualified.
- NO EXHIBITS ARE TO BE PAINTED. PAINTED EXHIBITS WILL NOT BE JUDGED.
- If you wish to just display your items, please contact the office to discuss them further.

WOODWORK CRAFTED**NOVICE**

Novice Class is open to exhibitors who have never won a prize in the Woodwork Section in a previous competition and have not entered on more than two previous occasions and have never entered an exhibit in the Intermediate or Open Classes.

- Class 31001:** Novice Small
Class 31002: Novice Medium
Class 31003: Novice Large

OPEN

Open Class is open to all exhibitors.

- Class 31004:** Open Small
Class 31005: Open Medium
Class 31006: Open Large

MARQUETRY & WOOD TURNING

Some examples of wood turning are spindle, plate or bowl turning, carving/hollow vessel turning, offset marquetry and other turned items, pens, jewellery boxes, ring boxes, etc.

Some examples of marquetry can be any size exhibit and must include timber inlay.

NOVICE

- Class 31007:** Novice Marquetry
Class 31008: Novice Spindle
Class 31009: Novice Face Plate
Class 31010: Novice Combination

OPEN

- Class 31011:** Open Marquetry
Class 31012: Open Spindle
Class 31013: Open Face Plate
Class 31014: Open Combination
Can include metal.
Class 31015: Intermediate Face Plate

WOOD SCULPTURE

Class 31016: Wood Sculpture - Open

WOOD CARVING

Class 31017: Wood Carving - Open

RESTORATION

Class 31018: Any Item
Must include a before photo.

REPURPOSE

Class 31019: Repurpose Item
You can use up to 20% new material. Please provide a photo where possible of items/articles that it is made from along with a description and use.

LASER ENGRAVING

Entrants must submit a wooden item produced using laser engraving. The design must be original and created by the entrant; pre-made or downloaded designs are not permitted.

Entrants must demonstrate the development of their design and provide evidence of the process. This should include photos where possible, along with a written description explaining the design, materials used, and the intended purpose or use of the finished engraved item.

Class 31020 Any Other Article
Please provide a photo where possible of items/articles that it is made from along with a description and use.

MOST ORIGINAL EXHIBIT - \$20

Prize: \$20 + Trophy + Sash

GRAND CHAMPION - \$50

Prize: \$50 + Trophy + Sash

SCHOOL ENTRIES

School entry is open to school groups.

Entry Fee: \$2.50

- Class 31021:** Small Woodwork Crafted
- Class 31022:** Medium Woodwork Crafted
- Class 31023:** Marquetry
- Class 31024:** Spindle
- Class 31025:** Face Plate
- Class 31026:** Combination
Can include Metal.

SCHOOL CHAMPION - \$50

Prize: \$50 + Trophy + Sash

SPONSORS

THANK YOU!

The Cairns Show Association wishes to record its sincere appreciation to the following Cairns Show Sponsors who have contributed to this event.

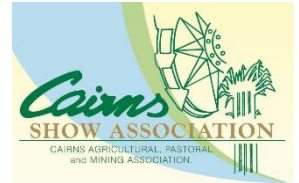

SPONSORS

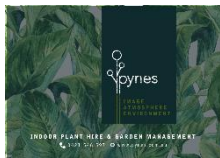



**CAIRNS
SHOW**



**15TH - 17TH
JULY 2026**

**SECTIONS
23, 24, 25, 26, 27,
28, 29 & 31
ARTS & CRAFT**

